

MOVIN' OUT

Our 44th year

P.O. Box 97
Slippery Rock
PA 16057

PRESORTED STANDARD
U.S. POSTAGE
PAID
WILLIAMSPORT, PA
PERMIT NO. 4

CHANGE SERVICE REQUESTED

Vol. 44 No. 3
March 2019

www.movinout.com

FREE COPY

"THE JOURNAL OF THE TRUCKING INDUSTRY"

9th Annual Eau Claire Big Rig Truck Show



This sharp looking tractor/tanker combo from Caledonia Haulers was one of the many trucks at the 2018 9th Annual Eau Claire Big Rig Truck Show. -Turn to pages 16 & 17 for story and more photos from the show. photo courtesy of Eau Claire Big Rig Truck Show -

Spring Maintenance and Preparing for Last Minute Snow Storms



Spring weather can be unpredictable, but regular maintenance checks can help you prepare your truck to handle anything, from a surprise snow storm to spring showers. Now is the perfect time to assess the impact winter has had on your truck in order to stay prepared for unexpected weather and to help avoid unnecessary downtime.

Proper tire maintenance is essential to your safety, fuel economy and uptime. This is especially true during volatile

weather conditions. Protect one of your biggest investments with routine tire checks and thorough pre-trip inspections. Check your inflation levels, tread depth and look for any visible damage or debris stuck in wheel components. Cold weather naturally causes tire PSI to drop; for every 10 degree change in air temperature, your tire pressure can change by one to three PSI. With the unpredictable air temperatures common in spring, it's a crucial time to keep tabs on your tire

pressure. Also look for steam or melted snow coming off wheel hubs, as this could indicate your wheel bearings are overheating. If necessary, give your tires a warm wash before inspecting them, as this can help you identify any potential warning signs of damage.

Whether your next route takes you through snow, rain or sunshine, these pre-trip checks can help reveal any tire damage that may have been hiding beneath snow or continued on page 10

No Kitchen? No Problem! Hot Meals In 5 Minutes!



PINEY FLATS, TN... If you are tired of high caloric, non-nutritious fast or just don't have time to stop for a sit-down meal, Chef 5 Minute Meals is the solution to your dining dilemma. The company offers 8 different meals that

self-heat in just 5 minutes using an innovative patent-pending heating system. No microwave, stove or hot water is needed. Chef 5 Minute Meals are prepared in a pressure-cooking system that eliminates 100% of food borne bacteria and, there-

fore, require no refrigeration and have a 3-year shelf life. The company plans to introduce a Mac and Cheese, and several other new meal selections in the near future.

Chef 5 Minute Meals is the continued on page 10

Truckers Against Trafficking Reveals "Everyday Heroes" Kenworth T680 in Washington, D.C.



WASHINGTON, DC... – In coordination with National Human Trafficking Awareness month, Truckers Against Trafficking (TAT) unveiled its 2019 Everyday Heroes Kenworth T680, at a press conference held recently at the National Mall in Washington, D.C.

On a brisk and snow-covered day in Washington, 50 members of the national media and sponsors of the Everyday Heroes Kenworth T680 turned out for a chance to listen to speakers, get a first-hand look at the special TAT Kenworth T680, and take a look inside

the Freedom Drivers Project, a mobile display featuring a video and artifacts from human trafficking survivors.

Featured speakers explained the importance of stopping human trafficking and the need to continue to raise awareness about the crime. The speakers included Kendis Paris, Truckers Against Trafficking executive director and co-founder; Kevin Baney, Kenworth assistant general manager of sales and marketing; Don Blake, new truck sales manager, Inland Kenworth – Phoenix; U.S. Rep. Andy Biggs (Arizona); Karl

Racine, District of Columbia attorney general; and John McKown, UPS driver and TAT ambassador.

"The press conference was held to help raise awareness for human trafficking, and we accomplished that goal through our Everyday Heroes Kenworth T680 and the Freedom Drivers Project," said Inland Kenworth's Don Blake, who serves as a TAT board member. "There was even a local driver who passed by and decided to pull his rig over to check out our special truck. He was inspired after learning about the

program, and wants to become TAT trained and to encourage others at his company to do so as well."

Those in attendance had the opportunity to look through the Freedom Drivers Project. "One woman told me that the Freedom Drivers Project was incredible, but the only thing missing was a box of tissues," said Blake. "As sad as it is to walk through the exhibit, it really does portray how terrible the crime of human trafficking is today. Hopefully, with the help of TAT trained members, we may one day bring an end to this crime."

Fighting human trafficking takes money to fund, and that is why the 2019 Everyday Heroes truck was built – as a fundraiser to offset TAT program costs. The Kenworth T680, valued at \$162,000 will be auctioned off live on Ritchie Bros., site in Phoenix on May 17.

According to TAT, 2,250 calls have been made to the national hotline by truckers which have helped identify over 1,100 victims of human trafficking, many of whom are kids.

"At the office of attorney general, we see kids every day and sadly we see kids who are victims of human trafficking," said Racine. "One of the earlier speakers spoke of the need to curtail trafficking by ending demand. The only way we can do that is if we enlist more eyes and ears on the roads, at the hotel, and at the transportation sites throughout this country."

The special Kenworth T680 is fully loaded with a 76-inch sleeper, 485-hp PACCAR MX-13 engine, and PACCAR 12-speed automated transmission.

Since its founding in 2009, over 680,000 people have become TAT educated and trained. With over 3.5 million truck drivers in the U.S. alone, drivers are considered the eyes and ears of the road. Drivers like John McKown, who is TAT trained and a driver for UPS, is one of those drivers looking to make a difference.

"I'm a fighter against human trafficking. This is where it gets tough because I'm a dad, a grandpa, an uncle, and a great uncle. But, more importantly, I'm in this fight to bring awareness to this horrible crime and someday, somehow make a difference in someone's life," said McKown.

The Everyday Heroes Kenworth T680 is designed to raise awareness for human trafficking, and encourage other drivers on the road to report suspicious activity to the National Human Trafficking Hotline (1-888-3737-888).

More information is available on the TAT website (www.truckersagainsttrafficking.com).



PAGE TRUCKING

NOW IS THE TIME TO JOIN THE NATION'S LEADING BULK TRANSPORTATION COMPANY!

See us at
M.A.T.S. Booth 91105-1
located outdoors

HIRING FOR OUR DUMP AND FLATBED DIVISIONS
HIRING FOR ALL 16 TERMINAL LOCATIONS

QUALIFICATIONS End Dump or Flat Bed Experience • Haz Mat Endorsement for End Dump
Coil Experience for Flat Bed • Clean MVR • Meet Company CSA/PSP criteria • Equipment Must Pass Federal DOT Inspection

HEADQUARTERS Page E.T.C. Incorporated 2758 Trombley Rd., Weedsport, NY 13166

1-800-233-2126

WWW.PAGETRUCKING.COM



MORE: SAVINGS.



TRAILER TIRES

\$199 PER TIRE
STARTING AT

WHEN YOU PURCHASE 8 OR MORE

TA TRUCK SERVICE®

MORE: BAYS. EXPERTISE. SOLUTIONS.®

Visit ta-petro.com or find us on   **TA**
Nasdaq Listed

Offer valid March 1 through April 30, 2019 on purchases of eight (8) trailer tires or more at participating TA Truck Service locations. Brands included in promotion vary by location. Price listed not valid on wide-based tires. Price does not include F.E.T., mounting labor, balancing, valve stems, state or local taxes.

Off The Beaten Path

by Pam Pollock

Sky Wheelies, Ridin' The Wave, Pogos and Burn Outs!



Althea, Steve and Declan with Kayla Blood, driver of the Soldier Fortune Monster Jam Truck.

Back in the late fall, I maybe/kind of/sorta got my not-quite-2-years-old grandson hooked on monster trucks. I don't even know how that happened, but it did. Soon we were watching Blaze and the Monster Machines DVDs and perusing the toy aisles for monster trucks. He was ecstatic to receive a very large Grave Digger truck for Christmas. My husband and I surprised him on his 2nd birthday in January with tickets to go to the Monster Jam Truck Show in February in Pittsburgh. His oldest sister declared that there was no way that she was attending the show, but his other older sister excitedly said that she would be attending. (His baby sister was too little to go.)

The show was 6 days ago. We all donned our Monster Jam shirts and gathered our Pit Passes and made the hour-long trek down to the 'Burgh. We were novices and it showed. We didn't get the autograph book, nor did we have an assortment of colored sharpie pens in our backpack. We did, however, pony up the exorbitant fee for the snowcones in the collector Grave Digger cups. We plowed through the piles of dirt and oohed and ahhhed at the trucks, which did indeed have monstrous sized tires. We stood in some lines and met drivers, Kayla Blood, the driver of the Soldier Fortune truck was extremely friendly and nice and very kind to the kids. Althea was sporting what can only be described as a diva outfit complete with a Piggie hat and a pink and white fur jacket and glitter sneakers. Drivers and fans alike complimented her on her attire!

Declan was overcome with excitement when we got to our seats and the show began. His favorite truck was "Zombie." He yelled and shook his fists whenever Zombie would make its run up the ramp and its zombie arms would wave and bounce.

Althea picked "Grave Digger" as her favorite. She would shyly wave and whisper, "Hiiiiiii" as Grave Digger roared around the track.

Gaga (me) had two favorite trucks - I liked El Toro Loco, the truck who resembled a bull.

sitting two seats away from me!

I will confess that I really did not know what a Monster Jam Truck Show was supposed to entail. I thought there would be lots of races and slamming into each other. That didn't happen and I was a little bummed out. The track at the PPG Paints Arena was smaller than some of the other venues, so we didn't see the big jumps and car crushing that other shows have. A couple of the trucks did roll over during our show. Was it wrong of me to cheer for that?

My favorite part of the show was the Freestyle Performance where the drivers took the trucks through a series of tricks. It was unreal to watch the drivers maneuver and tilt their trucks up until the entire truck was standing up on its front bumper/hood!

There's a whole other language for Monster Jam Truck aficionados, here's some terms that I never knew existed until now:

Auger In - When a truck crashes nose first, also called a "nose plant"

Bite - Traction from the tires
Blower - This forces air and fuel into the engine to create more power

Burn Out - Clearing mud by spinning the tires

Case It - When the peak of the obstacle hits the lowest part of the truck frame

Cut Tires - Process (completed by hand) of shaving off tire thread for traction

Cyclone - A donut at high-speed

Dry Hop - Clearing the starting line of loose debris by doing a burnout

Endo - A crash where the vehicle rolls end-over-end

Four Link - Adjustable suspension of a monster truck
Hammer - The throttle
Headers - Pipes for free-exhaust flow

Hole Shot - The first truck off the starting line

Hook Up - Accelerating quickly to getting traction

Hooking Clay - Track dirt that helps with traction

Nitrogen-Charged Shocks - Shock absorbers filled with nitrogen

Pogo - When a truck bounces on rear tires while doing a wheelie

Power Out - Using acceleration to keep from rolling over

Riding the Wave - Bouncing on the front tires

Roll Cage - Steel safety structure surrounding the driver

Sky Wheelie - A truck standing straight up with tires in air at a 90-degree angle

Slap Wheelie - Front of

the truck comes down from a wheelie and then goes back up

Teeter - Front tires are in the air while rear tires rock from side to side

Walk It - Single-tire wheelie involving hopping back and forth between the rear tires

Wheelie - When front wheels are up in the air and the truck is driving on its rear tires

You'll have to excuse me now, I have to get my El Toro Loco truck (yes, I now have my very own toy monster jam truck!) ready to hole shot onto the track. I plan on doing lots of cyclones and I hope I don't auger in or endo. I want to ride the wave while teetering and pogo'ing. I might even do some sky and slap wheelies!



El Toro Loco performing during the Freestyle Competition.

DIESEL INJECTION AND PARTS OF I-80 INC.

I-80, Exit 29 Barkeyville, PA

COMPLETE PARTS & SERVICE FOR ALL DIESEL ENGINES

\$80 per Hour Labor Rate

We can NOW upgrade your existing computer. Same day in-house service

- High output turbos
- High performance mufflers
- Custom built radiators
- Crankshaft dampers
- Performance exhaust manifolds
- Stainless Steel water tubes

Lucas Fuel Treatment

\$87 Per Case



Lucas Oil Stabilizer
\$92 Per Case



ALL LUCAS LUBRICANTS IN STOCK



Easy Access to I-80 Exit 29 • Truck Parking



(814) 786-7916

Open Monday - Friday 8:00 am to 5:00 pm

Owners
Ron Mahen
Bruce Mallinson

 **MAURY DONNELLY & PARR, INC.**
Baltimore MD.
INSURANCE SINCE 1875

WRITING TRUCK INSURANCE IN 48 STATES

- Bobtail-Physical Damage
- Liability
- Health and Disability Plans
- Specializing in Small Fleet and Owner/Operators

Call Gary C. Wirth
(800) 638-9202 x214
email: gwirth@mdpins.com

MOVIN' OUT
"THE JOURNAL OF THE TRUCKING INDUSTRY"

118 1/2 FRANKLIN STREET - P.O. BOX 97
SLIPPERY ROCK, PA 16057
PHONE: 724-794-6831 • FAX 724-794-1314
ISSN 1524-2684 www.movinout.com
E-Mail: movinout@zoominternet.net
All Rights Reserved

PUBLISHER: Steven M. Pollock
EDITOR: Pam Pollock
NATIONAL SALES: Autumn Kellogg, Dan Pollock, George Miller (717) 767-1523
FEATURES WRITERS: Matt Conrad, Henry Albert, Robert Conrad, Laura Hubka, Ken Hubka
CONTRIBUTING WRITERS: Rev. Robert E. Harris, Dr. Michael McGough, Bruce Mallinson, Fernando DeMoura, Roger Clark

FOUNDED IN 1975 BY Strickler W. Pollock

CIRCULATION AUDITED BY: CIRCULATION VERIFICATION COUNCIL

LISTED: srds, MACPA, NATSN, PMTA, PTP STOP, WOMEN IN TRUCKING

Advertising/Editorial Policy
Movin' Out welcomes the submission of articles, news releases, editorials & letters for publication. Articles should be no longer than 2 double-spaced pages, typed. No article - including those requesting anonymity will be published without author's name, address and phone number. Movin' Out reserves the right to refuse publication. Opinions expressed in letters and editorials are those of the author and not necessarily those of Movin' Out. The publisher assumes no responsibility or liability for typographical errors, and reserves the right to regulate ad placement and/or reject any ad or editorial.

SUBSCRIPTION ORDER

MOVIN' OUT  Professional Drivers Move America!

A Full Year 12 Great Issues \$20.00
(CANADA AND OTHER FOREIGN COUNTRIES \$22.00)
(Please allow 4 to 6 weeks for arrival of your first issue, no changes or new subscriptions will be accepted over the phone)

Name _____ E: Mail _____
Address _____
City _____ State _____ Zip _____

Enclosed check or money order with subscription blank and mail to:
MOVIN' OUT P.O. BOX 97 SLIPPERY ROCK, PA 16057

Kenworth is Exclusive Truck OEM Sponsor of PKY Truck Beauty Championship at 2019 MATS

KIRKLAND, WA... Kenworth announced that the company is the exclusive truck OEM sponsor for the 28th PKY Truck Beauty Championship March 28-30 at the Mid-America Trucking Show (MATS) in Louisville, Ky. The beauty contest is named in memory of Paul K. Young, who founded MATS in 1972.

"Kenworth has been a part of the Mid-America Trucking Show from the very beginning. As the manufacturer of the industry's most iconic trucks on the highway, it only makes sense for Kenworth's involvement in the beauty contest at MATS that showcases the very best custom trucks in North America," said Kurt Swihart,

Kenworth marketing director. "For anyone interested in trucks, this PKY Truck Beauty Championship is spectacular. The competition showcases trucks of the past and present in so many categories, from working trucks to purely show trucks. It's a must-see and a true highlight."

New this year are the "Top Three Kenworths in the Show" awards that recognize the top three Kenworth trucks in the PKY Truck Beauty Championship. The "Top Three Kenworth" owners in the show will receive a trophy, and a prize provided by Kenworth and PACCAR Parts. Kenworth will also present the "Top Three Kenworth" owners with an

all-expenses paid trip for two people to Ohio for a personal, red-carpet tour of the Kenworth Chillicothe plant, where Kenworth employees produce the World's Best Trucks®.

"We're excited about the special category that will recognize Kenworth owners and their special vehicles," Kenworth owners always come out strong to MATS and showcase their trucks, especially the legacy W900 with its long, distinguished history. We hope to see several of our newest model, the Kenworth W990, as well," said Swihart.

"It's always great to see a sea of Kenworths that look as good today as when they rolled off the assembly line,"

Swihart said. "And, with all the chrome and aftermarket additions Kenworth owners add, the trucks transition from a great-looking working truck to one that makes us stand back and say, wow!"

The presentation of the "Top Three Kenworths" winners will be a part of the PKY Truck Beauty Championship awards ceremony, which is scheduled for Saturday, March 30, at 10 a.m. in South Wing Conference Room B101.

For more information on the PKY Beauty Truck Championship, visit the 2019 Mid-America Trucking Show website (www.truckingshow.com/pky-truck-beauty).

Teamsters Challenge DOT Preemption Of California's Meal And Rest Break

WASHINGTON... THE International Brotherhood of Teamsters, Teamsters Local 848 and truck drivers for global companies have filed suit in the U.S. Court of Appeals for the Ninth Circuit, challenging the Department of Transportation's Federal Motor Carrier Safety Administration's decision to preempt California's meal and rest break guarantees for workers.

The petition filed today requests that the court reverse the Department of Transportation

(DOT)'s decision in its entirety due to the adverse impact it would have on thousands of workers and highway safety in California.

In addition to the International Brotherhood of Teamsters headquartered in Washington, D.C., and Teamsters Local 848 in Long Beach, Calif., and truck drivers for Sysco Corporation, NFI Industries, XPO Logistics and Pac 9 Transportation signed on as petitioners.

Teamsters Local 2785 in San Francisco previously filed a pe-

tition for review with the Ninth Circuit, seeking a reversal of the DOT's ruling.

The DOT decision would preempt California law which provides truck drivers with a 10-minute rest break after four hours of driving and a 30-minute meal break after five hours.

Teamsters Local 848 represents about 7,200 workers in Southern California, many of whom are commercial truck drivers whose meal and rest breaks could be impacted.

"Truck drivers keep our

economy running. I deliver food to hospitals and schools, loading and unloading up to 40,000 pounds in a single run. California's meal and rest break laws protect drivers like me from drowsy driving and injury, and keep our roads safe. That's why I am joining other drivers as a petitioner and asking the court to reverse the DOT's decision," said Charles "Lucky" Lepins, a member of Local 848 at Sysco.



Your Fleet Tracking Specialist
Serving Nationwide

GPS fleet tracking for as low as 11.99 per month.

717-554-7512

www.gpsharrisburg.com



KENWORTH OF PENNSYLVANIA

Cobra CB Radio

The Professional Driver's
Choice for Performance and
Durability

4w Power Output

40 Channel

Classic Styling



29 LTD Classic

29LTD

\$75.99

each*

NightWatch Electroluminescent

Illumination

29NW

\$97.99

each*



* with your Kenworth Privileges card. Offer code MARAPR1909

* offer expires 04/30/2019

www.kwofpa.com

Carlisle	(717) 766-8000	Shartlesville	(610) 488-1660
New Stanton	(724) 925-5000	Pittsburgh	(412) 778-0160
Dunmore	(570) 347-5671	York	(717) 848-8797
Clintonville	(814) 385-1040	Lancaster	(717) 898-2650
Muncy	(570) 308-3590		

**SEE US AT
M.A.T.S.
BOOTH #18068**

STOP WASTING YOUR MONEY ON FUEL

**LEARN HOW OUR TUNING
SOLUTIONS CAN GREATLY
IMPROVE YOUR FUEL SAVINGS**

TOLL FREE: 1-855-932-0060
www.DieselSpec.com

PERFORMANCE

High Performance Diesels with Bruce Mallinson

Be careful squeezing the nickel when it comes to preventative maintenance on the truck that makes your living possible and supplies your family with a car, food, and a roof over their heads. What is the most important item in your life? This torsional damper which we removed from an ISX has 680,000 miles on it. The silicone fluid has been hard for quite some time negating the purpose of the damper, to remove torsional vibrations. The following is a list of what fails when the torsional damper has

outlived its useful life: broken crankshafts, broken camshafts, broken alternator brackets, broken AC compressor brackets, broken flywheel bolts, broken flywheel housing bolts, knocking the springs out of the clutch disc, broken input shaft of the transmission, worn out U-joints and carrier bearing. I want you to think about this Kenworth with the destroyed torsional damper. We are replacing the damper, installing the mercury filled engine balancer and the timing case cover. But what else is about to

fail? This truck could turn out to be a mechanical disaster. It would be interesting to follow the failures of this truck for the next 5 years. Think about the word "LEMON", how many times have you heard someone say their truck is a LEMON. Was it? Or were the problems created because of a faulty torsional damper. Something else to think about, the person assembling this engine at the factory could have dropped this damper thus putting a dent into the outer cover and rendering the damper useless.





PERFORMANCE
TUNING

CUSTOMIZED DIESEL ENGINE DIAGNOSTICS & TUNING
ADVANCED PERFORMANCE & BETTER FUEL ECONOMY

PITTSBURGH POWER
PERFORMANCE TUNES
RIGHT AT YOUR FINGER TIPS!

Find a performance tuning
location near you at
pittsburghpower.com
or contact our sales team to
purchase yours today.

WWW.PITTSBURGHPOWER.COM

3600 South Noah Drive
Saxonburg, Pa 16056
P: 724-360-4080
F: 724-360-4085

Follow us



@BurghPower

Maybe it was dropped at the damper manufacturing facility or during transit. If your engine isn't running smooth, don't ignore the problem, it will only manifest into greater problems.

Our dyno is our best diagnostic tool when it comes those hard to find issues. We recently had a customer visit us because his CAT 6NZ was bucking, sputtering, hesitating, and generally running rough. When we ran it on the dyno, we found this was no stock 6NZ, but a fully built motor with a performance cam and marine injectors. It put down 840 HP and 2500 TQ on the first pull all while running rough. Once we reviewed the data, the source of the problem became clear. Fuel pressure was dropping from about 90psi to 30psi from before the cylinder head to after the cylinder head. With a sight glass in the fuel line, we verified there was air in the fuel. After some more digging, we found the primary air filter housing was cracked letting air in the fuel. As for the lack of fuel pressure and/or volume, it had stock fuel lines and fuel pump and it seemed those marine injectors demand more fuel volume/pressure than what is standard for a 6nz. The customer opted to make the repairs himself. For experimental purposes we put a FASS system on that increased fuel pressure and reduced air in the system. The result was 870 WHP and 2600 WTQ which means this 6NZ was making 1,000 flywheel HP (accounting for 15% drivetrain loss). We encourage owner operators to save money by learning to repair their own trucks, but if you get stuck with a problem you just can't figure out bring your truck in. We'll help you figure it out and put you back

on track.

Fuel mileage, cruise control Do you drive your truck, or does it drive you? We all love cruise control; however, it's best used in automobiles, empty pickup trucks, and motorcycles. Anything pulling a trailer should very seldom use cruise control unless you are on dead level terrain or slight downhill. If you listen to our radio show with Kevin Rutherford (The Power Hour, on Tuesdays from noon to 2 pm EST), all the owner operators that call in and complain about poor fuel mileage do not have a turbo boost gauge or do not know what it means. My first question is always, "how much boost do you use when driving on the level and the wind is not blowing." Many times, the answer is, "this is an old fleet truck and it didn't come with a boost gauge." My friends, the boost gauge kit is \$68.00 and is very easy to install, in fact you can install it in your driveway or truck stop parking lot. If they have the boost gauge the answer is usually around 18 psi on the level. My fellow trucking friends, there is NO fuel mileage at 18 or more psi of boost on the level. There could be many reasons why it is taking all that boost to move the rig at the speed you have chosen. First, try slowing down 5 mph and see if the turbo boost drops 5 psi or more. Here is a list of other possibilities: the turbocharger on the engine could be too small creating too much back pressure, the mufflers could be clogged or too restrictive, the tires have high rolling resistance, the gap between the trailer and cab is too far (air can only jump 36 inches at highway speed), the load is pulling hard

or the trailer is loaded wrong, the exhaust manifold is stock and will not allow the exhaust to escape from the engine, the truck is geared wrong, a bad ECM program, or you are NOT paying attention to the boost gauge and using cruise control and the terrain is rolling. I feel driving is 66% of fuel mileage. Recently I had an owner-operator call and could not drive his DDEC5 under 18 psi of boost on the level, he was from Minnesota and never gets East so I could not see the truck. We have long conversations and I realized someone installed a 12.7 turbo on his 14-liter engine. I shipped him the performance turbo we use on a 14-liter Detroit and with the same load and speed, his boost went from 18 psi to 8 psi. That was a gain of 1.25 mpg, less exhaust gas temperature, and a more free running truck. If your engine has EGR and equipped with a Variable Geometry (VG) Turbocharger, the variable geometry section of the turbine housing may not be opening properly, soon enough or not enough. All three symptoms will lower the fuel mileage, cause the truck to drag, and increase the exhaust gas temperature. Our engineering department can design an ECM program for your engine and your driving conditions. As you can see, many items determine fuel mileage, it's up to YOU to make the changes to your truck and your driving style to improve your fuel mileage.

Written by: Bruce Mallinson and Andrew Wilson, Pittsburgh Power Inc., 3600 S. Noah Dr. Saxonburg, Pa. 16056 Phone 724-360-4080 Website: Pittsburghpower.com



Opportunities in the mirror may be closer than they appear.

Did you apply to be a Burris Driver but didn't yet meet the qualifications? Have you been building your career and experience since then?

We have a growing fleet and a growing need for drivers.

Before driving on, take a look back at what we have to offer.

Let's chat about long-and-short distance employment opportunities, with same-day routes available at various locations.

BurrisJobs.com/drivers
1.877.287.7479

HONOR FOODS
A Value Added Redistributor
Honor Foods is a foodservice redistribution division of Burris Logistics.

Understanding Oil Contaminants



by Tom Bock

defective cooling fan will cause overheating issues, as well as pulling a heavy load upgrade for an extended period of time. The number one reason for overheating occurs when the engine oil levels are not properly maintained and there is insufficient oil to properly dissipate the heat caused by combustion. A close second is the flow of oil not maintained at normal operating flow rates. This is due to oil filter or galley way blockage caused by sludge, defective oil pump, improperly maintained oil filters or oil leakage. Engines today run hotter with double turbochargers and some engines are experiencing gelling issues in filters caused by antifreeze intrusion that restricts flow and lowers oil pressure. Checking and topping off oil frequently, changing filters timely, maintaining engine to avoid leaks and paying attention to oil pressure will usually prevent overheating issues. Remember, running one gallon low reduces 10% of the engine's oil, placing extra stress on the remaining oil to dissipate heat.

flow filter with a secondary by pass filter will help decrease the accumulation and allow for longer useful life of the oil.

Liquid contaminants; water, diesel fuel and glycol contaminate oil causing the formation of acid, increasing oxidation, sludge and deterioration of additive chemicals. The water reacts with the sulfur and nitrogen in oil to form sulfuric and nitric acids as well as adding oxides to oil that corrode and rust engine parts. Diesel fuel will decrease the viscosity of the oil and affect the film strength of the oil to properly bond with metal parts. It is this oil film that protects engines from metal to metal wear. Once the film is compromised the wear levels increase rapidly. Glycol does not enter the oil during normal operation but by some defect in coolant system causing intrusion. Unfortunately, since the advent of EGR and Oil Coolers there is an increase in glycol intrusion in engines

Using a bypass filtration system that removes both solid and liquid contaminants will extend drain intervals and the life of your engine, reduce oil maintenance expenses and put more \$\$\$\$ to your bottom line. Stop by OPS Booth 68216 at Mid America Truck Show to learn more about systems available,

Any questions or suggestions for topics for this column please email me at: tbock@horizoncp.biz

Since the early 1900's we have known that the base oil does not break down, it becomes contaminated with solid and liquid contaminants and the additive package loses potency to properly protect the engine. The used oil can be recycled as a base oil, by removing the contaminants and reformulating the oil with a new additive package. The additives in lube oil fail when oil is over heated, contaminated with liquids (fuel, water, antifreeze) or solid particulates (soot, wear metals) that cause the oil to lose the ability to properly protect the engine from metal on metal wear damage. Keeping oil free of these contaminants and maintaining proper oil levels will reduce the rate of deterioration of your oil and keep the engine running more efficiently.

Having a failure of a cooling system with a blown hose or

Solid contaminants, soot, dirt, and wear metals will eventually accumulate in quantities that will affect the oil's ability to properly flow and dissipate heat. Soot, dirt, oil and water will create sludge that blocks galley ways and filter operation. Wear metals will become trapped between tolerances and cause additional wear. Using a good quality full

More Than a Fuel Saver

- Decreased Drag
- Increase Fuel Mileage
- Increased Vehicle Stability
- Reduces Rear Spray



262.394.5752
www.airtab.com

See us at M.A.T.S. Booth # 68232 West Wing

SAUERS



Owner Operators Needed

WE ARE CURRENTLY EXPANDING OUR FLEET

Run Regionally in PA, OH, NY (Upstate), KY, and various lanes

East of the Mississippi • Pull Company Dry Vans

• No Age Restrictions On Power Units

- No Forced Dispatch • Drop and Hook - No Touch Freight • Home Weekends •
- Percentages Paid on 100% of Gross • 100% of Fuel Surcharges •
- 4% Bonus for East Bound Lanes • Fuel, Road Taxes and Permits Paid •
- FleetOne Fuel Card • Safety Bonuses and Awards • No Escrow Deducted •



Cranberry Township, PA
(800) 245-1944 ext. 221
www.wcsauers.com

TBS

DRIVES MY CASHFLOW SO MY DRIVERS ALWAYS GET PAID ON TIME

PATRICK KINGARA
PAMEKIT ENTERPRISES, INC.
6 TRUCKS STRONG ESTABLISHED 2006

TBS CLIENT SINCE 2011

THE FULL STORY AT TBSFACTURING.COM/PAMEKIT

Same Day Cash For Your Invoice • Quick Pay Match
Fuel Advances • Fuel Discounts
855-772-0548 • TBSFactoring.com



Drive 200,000 miles or more between oil changes with

ecopur

Continually cleans your engine's oil



- Lower maintenance costs by up to 80%
- ROI in as little as 10 months
- Effectively removes solid and liquid contaminants
- Safely extends oil change intervals using OPSTruTest oil and engine wear analysis



Kevin Rutherford

"The answer is yes, it really works, and yes you really can drive 200,000 miles or more between oil changes."

Kevin Rutherford, Host Trucking Business and Beyond Sirius XM channel 146

Also endorsed by Bruce Mallinson - Pittsburgh Power



866-Oil-Pure
(866-645-7873)

www.ops-1.com



Find us on Facebook

Keyword Oil Purification Systems inc.

SEE US AT M.A.T.S. 3/28 - 3/30
BOOTH #68216

MAWSON & MAWSON, Inc.



America's Oldest Class 1 Carrier
—Since 1895—

RECRUITING BLITZ!!!

\$1000.00 SIGN-ON BONUS!

All-Driver Incentives

- First-In/First-Out • Weekends Home
- FREE Electronic Bill Scanning
- Weekly Settlements/Direct Deposit
- PrePass • Reitnouer® Trailers Available

Company Drivers

- New Equipment • Compensation Based on Experience 27% - 28%
- Excellent Medical Coverage
- Matching 401K Plan
- Paid Vacation • Paid Holidays
- Additional 1% Bonus Based on Annual Revenue Goal

Independent Contractors

- First-In/First-Out
- Up to 78% Gross from 100%
- All State Road & Fuel Tax Paid by Us
- No Forced Dispatch
- Bobtail, Collision, Plates Available

Requirements

- Must Have a Valid Class A CDL
- Must Have a Current DOT Physical
- Paid Training Available for Non-Steel Haulers (w/2 yrs OTR Experience)

Company Drivers Can Earn in Excess of **\$70,000**
Home Weekends! Paid Holidays and Vacation.

1800 E. Old Lincoln Hwy
Langhorne, PA 19047

215-208-1544

www.facebook.com/mawsonandmawsoninc

www.mawsonandmawson.com

Call Bill in Recruiting @ 215-208-1544

U.S. Department of Transportation Announces \$705.7 Million in Emergency Relief for Road and Bridge Repairs

WASHINGTON, DC... The U.S. Department of Transportation's (USDOT) Federal Highway Administration (FHWA) today announced more than \$705.7 million in Emergency Relief (ER) funds to help 34 states, as well as American Samoa, Puerto Rico, and the U.S. Virgin Islands, make repairs to roads and bridges damaged by storms, floods, and other unexpected events.

"The Department is pleased to reimburse states and territories that have made critical repairs to their transportation infrastructure following natural disasters such as wildfires, storms, and floods," said U.S. Secretary of Transportation

Elaine L. Chao.

FHWA's ER program reimburses states, territories, and federal land management agencies for eligible expenses associated with damage from natural disasters or other emergency situations. The funds help to pay for the reconstruction or replacement of damaged highways and bridges along with the arrangement of detours and replacement of guardrails or other damaged safety devices.

More than a fifth of the total amount provided today—about \$153 million—will be used to pay for repairs to damage caused by Hurricanes Harvey, Irma, and Maria. There are also funds directed towards

other severe weather recovery efforts, including the wildfires in California.

This Emergency Relief funding includes awards of:

- More than \$12.5 million to repair damage to roads and bridges from wildfires in California in 2018.
- \$1.2 million to repair US Highway 550 Red Mountain Pass in southwest Colorado, after it sustained damage from a rock slide.
- \$19.5 million to repair damage caused by Hurricane Michael's heavy winds and significant storm surge flooding roadways throughout the Panhandle area.



www.emwayinc.com

98% PAID TO OWNER/OPERATORS

WHAT WE OFFER:

- No down time
- Freight for flats, steps, vans, reefers
- Trailer rentals
- Fuel cards with discounts!
- Weekly settlements and direct deposit
- Assigned logistics coordinator who will preload your truck 24-48 hours in advance or assist you in self dispatch

A COMPANY THAT CARES!

302-450-3272

www.emwayinc.com

**See us at
M.A.T.S.
BOOTH
#60013**



Liberty
TIRE RECYCLING

Hiring
Drivers
&
Helpers
Home Nightly

Big Hiring Bonus!

With over 30 sites and more than 2,000 employees, Liberty Tire Recycling is the premier provider of tire recycling services in North America. By recycling more than 150 million tires annually, Liberty reclaims about 2.2 billion pounds of rubber for innovative, useful products.

Call 833.305.4237 and talk to our recruitment team for more information.

Industry News Briefs

Small-Business Truckers Respond To Senate Hearing On Infrastructure

Among the many issues raised at a hearing held by the U.S. Senate Committee on Commerce, Science and Transportation, two caught the attention of small-business truckers. One was connected directly to infrastructure and one was not, but both are closely related to highway safety.

Truck parking and CDL requirements were brought up during the "America's Infrastructure Needs: Keeping Pace with a Growing Economy" hearing, both of which the Owner-Operator Independent Drivers Association and its members have an interest.

"We appreciate some of the witnesses highlighting the truck parking crisis," said Todd Spencer, OOIDA President. "For too long, Congress and federal transportation agencies have done very little to address this issue. Truckers need more safe places to park, not more studies that do nothing to increase or preserve capacity. This is a critical highway safety issue that deserves dedicated federal funding."

Regarding another issue brought up during the hearing, OOIDA expressed objection. The American Trucking Associations said that in order to address a driver "shortage," that the age requirement to obtain a commercial driver's license should be lowered from 21 to 18.

"If safety is the top priority when considering a change to a regulation, when it comes to age, the number should be raised, not lowered!" said Spencer. "We also disagree that there is a driver shortage. There is very high turnover, or churn, but no shortage."

OOIDA has long opposed efforts to lower the age for driving a large truck and refers to the claims of a driver shortage as mainly mythical. OOIDA also contends that any issue with retention could be mitigated with other solutions that would be safer for all highway users. For example, compensation has been shown to be tied directly to highway safety, as revealed in a study by Michael Belzer, an economics professor at Wayne State University. His study suggests there is a strong correlation between truck pay and highway safety.

"Most carriers with high turnover do so by design," said Spencer. "They could deal with driver turnover by offering better wages and benefits and improved working conditions. But putting younger drivers behind the wheel of a truck isn't the solution because it does nothing to address the underlying issues that push drivers out of the industry. It merely exacerbates the churn."

ATA Truck Tonnage Index Increased 6.6% in 2018

Arlington, VA... American Trucking Associations' advanced seasonally adjusted (SA) For-Hire Truck Tonnage Index increased 6.6% in all of 2018 – the largest annual gain since 1998 (10.1%) and significantly better than the 3.8% increase in 2017.

That annual gain was realized despite a decrease of 4.3% in December to 111.9, down from November's level of 116.9.

"The good news is that 2018 was a banner year for truck tonnage, witnessing the largest annual increase we've seen in two decades," said ATA Chief Economist Bob Costello. "With that said, there is evidence that the industry and economy is moderating as tonnage fell a combined total of 5.6% in October and November after hitting an all-time high in October." - November's change over the previous month was revised

down to -1.3% (+0.4% was originally reported in our press release on December 18).

Compared with December 2017, the SA index increased 1.4%, the smallest year-over-year increase in 2018. In November, the index was 5.8% above the same month in 2017.

The not seasonally adjusted index, which represents the change in tonnage actually hauled by the fleets before any seasonal adjustment, equaled 107.8 in December, which was 7.8% below the previous month (117). In calculating the index, 100 represents 2015.

Trucking serves as a barometer of the U.S. economy, representing 70.2% of tonnage carried by all modes of domestic freight transportation, including manufactured and retail goods. Trucks hauled 10.77 billion tons of freight in 2017. Motor carriers collected \$700.1 billion, or 79.3% of total revenue earned by all transport modes.

ATA calculates the tonnage index based on surveys from its membership and has been doing so since the 1970s. This is a preliminary figure and subject to change in the final report issued around the 10th day of the month.

ATA President Urges Congress to Move Forward on Needed Highway Funding

Arlington, VA... American Trucking Associations President and CEO Chris Spear testified before the Senate Commerce, Science and Transportation Committee about the urgent need to address the nation's failing infrastructure, pressing the committee to put forward a real solution that includes new revenues.

"Just last week, chunks of falling concrete struck cars traveling under bridges in California and Massachusetts," Spear said. "We are no longer facing a future highway maintenance crisis – we're living it – and every day we fail to invest, we're putting more lives at risk."

The nation's crumbling and failing infrastructure is taking a tremendous toll on Americans' time and their pocketbooks, and has impacted the trucking industry in a significant way.

"Trucking now loses \$74.5 billion sitting in gridlock. That equates to 1.2 billion lost hours or 425,000 truck drivers sitting idle for an entire year," he said. "These are the regressive costs of doing nothing. And they are

reflected in the prices we all pay. These costs to consumers and economy are measurable... and they can and should serve as offsets for new spending on our nation's infrastructure."

To address the nation's need to re-invest in its roads and bridges, Spear again pushed forward the Build America Fund – a 20-cent per gallon fee at the terminal fuel rack phased in over four years that would generate billions in new revenues for investment.

"Trucking pays for nearly half the Highway Trust Fund, and we're willing to pay more," he said. "The Build America Fund would increase the price of fuel 20 cents per gallon at the fuel rack – just a nickel a year over four years – generating \$340 billion over 10 years. This new revenue is real, not fake funding like P3's and asset recycling."

"The Build America Fund is the most conservative proposal... costing less than .01 cent on the dollar to administer, versus up to .35 cents a dollar for tolling schemes," Spear said.

Oregon DMV Seeks Qualified Providers For Commercial Driver Testing

SALEM, OR... Oregon DMV is looking for new skills test providers for commercial driver licensing across the state.

DMV encourages businesses and organizations that can provide CDL skills tests to apply with the Oregon Department of Transportation for the CDL Third Party Testing Program.

Once ODOT awards providers with a contract in this program, they will be authorized to administer CDL skills tests on behalf of DMV.

In the next few months, DMV will post a Request for Proposal (RFP) for these services on the [Oregon Procurement Information Network \(ORPIN\)](#). Any entities wishing to submit a proposal response must be registered on ORPIN in order to do so. Registration is free.

If you are interested and want to find out if you are qualified, the applicable federal regulations can be found [here](#). There will be additional qualification requirements, which will be stated in the forthcoming RFP.

Federal regulations provide a foundation for what is required of CDL third-party testing businesses.

If you are new to Oregon public procurement, or would like training or assistance with how to successfully compete in the government marketplace, the [Government Contract Assistance Program](#) has free tools available.

Prior to the posting of the RFP, if you have questions related to the CDL program, its regulations, or the process by which you can become a third-party tester, contact the DMV Third Party Programs Team by phone at (503) 945-5118, or by email at Nick.g.hopper@odot.state.or.us

Once the RFP has been posted in OPRIN, all questions must be directed to the single point of contact, Stephanie Lehman. Stephanie can be reached by email at Stephanie.k.lehman@odot.state.or.us

Dish Network-Satellite Television Services. Now Over 190 channels for ONLY \$49.99/mo! HBO-FREE for one year, FREE Installation, FREE Streaming, FREE HD. Add Internet for \$14.95 a month. 1-800-219-1271

CARS/TRUCKS WANTED!!! All Makes/Models 2002-2018! Any Condition. Running or Not. Competitive Offer! Free Towing! We're Nationwide! Call Now: 1-888-368-1016

ALWAYS
Moving FORWARD
WITH PRIDE, INTEGRITY, AND YOU.
40
100% OWNER OPERATED FOR OVER FORTY YEARS

Mercer Transportation has built a family of Contractors on the foundation of honesty, professional freedom and experience! We offer good money and pay you FAST... plus you'll enjoy generous discounts on fuel, tires and insurance.

With more than 40 years' experience, not to mention our one-of-a-kind family atmosphere, you'll see quickly why Mercer Transportation is The Owner Operator Company!

MERCER
TRANSPORTATION COMPANY

MERCERTOWN.COM
CONTACT US TODAY!

COME SEE US AT MATS
BOOTH #19236

1-888-241-4830

LAW OFFICES OF
ECKERT & ASSOCIATES, P.A.

www.DowntimeClaims.com

Trucking Attorneys

- Trucking Accidents
- Insurance Claims
- Loss of Use/Income/Loads

FREE Initial Consultation
(904) 278-7688

No Kitchen? No Problem! Hot Meals In 5 Minutes!

continued from page 1

brainchild of Chef Barry Sen-del. All of the recipes are Barry's and made to his specifications. In 2005 Defense Logistics Agency (DLA), a US government agency that helps with natural disasters in the USA, tasked Chef 5 Minute Meals to supply some 5 million meals for the victims of the Katrina Hurricane. The company relocated from Canada to Piney Flats, Tennessee to accommodate future needs of DLA and has since become one of two prime suppliers to FEMA for natural disaster response. The criteria was simple – Chef 5 Minute Meals are nutritious high in protein and low in sodium and calories with no preservatives or additives. The meals contain 400-600 grams less sodium than most frozen meals. They have a 3-year shelf life and a patent-pending self-contained heating element in each meal kit. Most importantly, they taste great.

Chef 5 Minute Meals realized that their meals would be ideal for Professional Truck Drivers. The product provides a delicious and nutritious hot meal whenever they want one (*Anytime Time, Anywhere!*) enabling drivers to better manage their time and maximize their earnings. The meals are generally found reasonably priced at under \$6.99 each.

Chef 5 Minute Meals are available in individual kits, cases containing 6 or 12 meals, and 72 hr. emergency kits that provide an economical 18 servings. Chef 5 Minute Meals are made in the USA. They are never

freeze dried or dehydrated. You can choose from Chicken Cacciatore, Chicken Pasta Parmesan, Beef Chili with Beans, Spaghetti with Meatballs, Beef Stroganoff, Beef Stew, and Vegetable Lasagna.

Chef 5 Minute Meals puts the "fast" in breakfast with a Cheese Omelet with Beef Chili and Beans that is ready in just minutes. Also available for hot days are "Cool Meal Solutions" – Chicken Vegetable or Tuna Vegetable Salad, mixed with "real" mayonnaise in a kit that includes 2 whole wheat tortillas, 2 electrolyte beverages and a Grand Canyon Bar meal replacement bar. The Grand Canyon Bar is an energy bar with lots of sweet and nutritious honey.

Chef 5 Minute Meals can be ordered direct from www.chef5minutemeals.com or online at www.Amazon.com. The company is working towards setting up distributor partners in the *Travel Plaza industry*.

Over the past three years Chef 5 Minute Meals has donated over 250,000 meals to charities, churches, and homeless shelters to help feed the hungry.

If you would like to taste a Chef 5 Minute Meal, visit them at the Mid-America Trucking Show in Louisville, Kentucky in Booth #67193 in the West Wing. In advance of the show you can phone them at 855-926-0092 or 423-926-0092 for more information.

Their email address is: getmeals@chef5minutemeals.com.

Spring Maintenance and Preparing for Last Minute Snow Storms



continued from page 1

debris. Periodic inspections may also reveal alignment wear on your tires. Stop into a TA Truck Service location to have your wheels inspected by one of our TIA-certified technicians if you discover alignment wear or other severe damage during one of your preventive checks.

Winter can be tough on more than just your tires. Corrosion often occurs naturally over time, but major causes of corrosion are multiplied during winter. Acidic salt solutions are essential to keep our roadways safe, but they can also do significant damage to your truck's electrical system.

No matter where you're headed, this is also a good time to evaluate the impact of cold temperatures and harsh chemicals on your truck's electrical system. The acidic nature of highway de-icers will erode any exposed connections or wires on your truck in no time. These chemicals can also eat away at the frame, undercarriage and other exposed components on your truck. A quick way to test your electrical circuit is to turn

on your lights and look for any dimly lit bulbs. If any lights are dim, it could be an indication of resistance in the circuit and you should have your system

inspected by a professional technician.

On top of corrosion from de-icing chemicals, your truck's batteries are exhausted from working overtime during long, cold days. This places an even larger demand on your electrical system, which makes periodic alternator output and battery tests so important. It's also a good practice to have your cables and connections tested to help detect corrosion or loose connections.

Regular preventive maintenance checks can help you identify any existing issues that may have been caused or worsened by winter, and they can also help you prepare for the warmer days ahead.

If you don't feel comfortable completing these inspections yourself, stop into a TA Truck Service location near you to have one of our professional technicians take a look. In addition to electrical system inspections, battery performance inspections and advanced diagnostics tests, we also provide unique services such as aftertreatment maintenance, wheel alignment services and more at select sites across the country.

Whether we're diagnosing an engine fault or making sure your wheels are properly aligned, our goal is always to resolve any issues and get you back on road safely and on time.

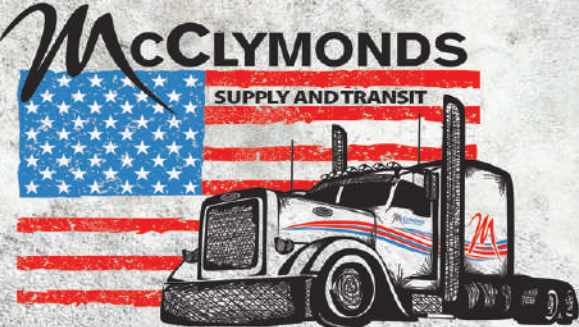

McClymonds
SUPPLY AND TRANSIT

**CLASS A & B
CDL DRIVERS**

Be home every night and still make a good living.

**Tri-Axle Dumps • Tractor Trailer Dumps
Pneumatic Bulk Tanks
Roll-Off Tri-Axles • Heavy Haul**

LATE MODEL PETERBILT TRACTORS

Give us a call 724.368.8040

296 Currie Road Slippery Rock, PA. www.McClymonds.com

DELICIOUS

SELF-HEATING MEALS

Easy as one, two, three



1 Activate heating pad

2 Slide tub back into the oven box



3 Oven box heats in 5 minutes



How does working with Chef 5 Minute Meals benefit trucking companies and drivers?

- Increase revenue with less down time.
- Hot home-styled meals without stopping.
- Log more miles.
- Assurance of always having food, regardless of weather, traffic, or delays.
- "Ready-To-Eat" meals requiring no refrigeration, open flame, or additional water.

www.chef5minutemeals.com

Visit us at the Mid-America Trucking Show in Louisville, Kentucky

ENTER TO

WIN!

A YETI COOLER!



The Leader In Self-Heating Meals

SEE HOW IT WORKS
(POUCH OVEN)



SEE HOW IT WORKS
(BOX OVEN)



The More Fuel, The More Waste Heat Part 3. Preventing The Exhaust Manifold From Cracking



I've worked on a few projects with some owner operators who run marine HK cams and injectors whose goal is to run a Series 60 between 700hp and 900hp. That's a lot of fuel and a lot of heat to deal with. One of these owner operators is on his fourth exhaust manifold and he asked me why and what he can do about it.

The three-piece exhaust manifold used on trucks is the first component that's exposed to exhaust gas that isn't protected by the coolant system. The marine TK60 and marine HK60 Series 60 are designed to deal with all that heat and have a one-piece exhaust manifold with a water jacket. It doesn't stop there however...the exhaust side of the turbo also has a water jacket and some vessels even have a "wet" exhaust after the turbo to further cool things down.

Marine applications have the luxury of water to water cooling and that's much more efficient than water to air cooling which is what nearly all other Series 60 applications rely on, including trucks.

So even if you could get the marine exhaust manifold



If these mounts were installed, this wouldn't have happened.



This was the only mounting point that was preventing the ECM from falling off.

and turbo to fit in a truck, you'd still need one really, really, big radiator to cool your coolant back down.

If cutting back the fuel isn't an option, then the most practical solution in most cases is a thicker aftermarket exhaust

manifold with more thermal mass than the factory manifold.

Have you ever crawled underneath a truck in the middle of winter and pull an ECM only to have one of those little blue rubber mounts fall off and get lost in the snow? I have and if

it's happened to you it's likely you had the same thought I did when it first happened to me. Are these rubber donuts really necessary? There are 7 more holding the ECM to the block and my fingers are cold.

The photos in this article show what can happen if you give in.

Nearly all ECM cases are made out of aluminum. The problem with aluminum is that it's soft and when it comes in contact with a bolt the bolt wins. The vibration isolator mounts protect the ECM case from coming in direct contact with the mounting bolts. I did a DDEC case transplant last week on a P23519308 DDEC IV because of how much damage the mounting bolts did by coming in direct contact with the ECM case.

Written by Fernando DeMoura, Diesel Control Service-Phone 412-327-9400 Website: www.dieselcontrolservice.com

APLACEFORMOM has helped over a million families find senior living. Our trusted, local advisors help find solutions to your unique needs at no cost to you. 1-855-204-5180

Antique Car or Farm Equipment to sell? Advertise with us in over 100 publications. You choose where you want to advertise. 800-450-6631

GET 2 WEEKS FREE OF ADVERTISING when you purchase 2 weeks. Learn more at macnetonline.com or give us a call at 800-450-6631.

MATS Show Special!
The Gator Traction System
Pricing Extended
Through June 2019
JUST **\$79⁹⁵**
Chain Up Quickly & Safely!
Order Online - www.gatortraction.com

TICKETS
We win 9 out of 10 Cases!
FREE REVIEWS
Spanish, Russian, Hindi/Punjabi, Korean
30 Years Fighting for the Trucker!
1-800-525-HAUL
NATIONWIDE CANADA
ACCREDITED BUSINESS
Company Programs
GSA/DAC HELP
24 hrs (7days a week)
All Legal Problems
www.AmericanTruckersLegalAssoc.com
* Fast performance of attorneys who represent ATLA members does not guarantee future performance.

DCS
DIESELCONTROLSERVICE.COM

DDEC Repairs - DDEC rebuilds - DDEC program
Dyno proven fuel mileage and horsepower
Detroit Diesel DDEC III & IV specialists

DCS rebuilt DDEC IV ECMs **\$1150**
DCS rebuilt DDEC III ECMs **\$1000**
Flash code 53 fixed! DDEC memory replacements **\$500**
DDEC III & DDEC IV Fan, Jake and misfire problems repaired
DDEC OE Battery replacements **\$150** when done with triple play programs

DCS Series 60 TRIPLE PLAY ECM PROGRAMS
You choose when to switch to your high fuel mileage program, your high horsepower program and when to switch back to your stock ECM program.

- 3 DDEC ECM programs in 1 (for DDEC III and IV)
- Change between 3 different dyno proven fuel, timing, engine response, and rpm limit settings on the fly.
- Combine a 370 hp eco mode, your stock program, and a 700 hp 2400 RPM high power program for maximum flexibility
- No sensors cheated
- The only install needed is a switch to the ECM and the install kit wiring harness and switch are included
- Programming & install kit for **\$999** 24 hour turn around time*
- Customizable torque outputs or limiters from 1200 to 2400 rpm
- Customizable timing control
- Available only at DCS

Diesel Control Service #395
1151 Freeport Rd,
Pittsburgh, Pa 15238

412-327-9400
www.dieselcontrolservice.com

BESTfit
ENGINE COOLING

OVER 1,000 RADIATORS, CAC's & AC CONDENSERS IN STOCK!
RADIATORS - CHARGE AIR COOLERS - AC CONDENSERS

40 YRS ENGINE COOLING EXPERIENCE

855-220-8608
www.bestfittruckparts.com
WAREHOUSING IN BOTH JOPLIN, MO & POTTSVILLE, PA

TRUCKING SHOW
March 28-30, 2019
Louisville, KY
See Us At Booth #13236!



STAR FLEET MATTRESS
FOR RV, SEMI-TRUCKS, BOATS

TRANSPORT YOURSELF TO M.A.T.S. BOOTH# 67245

Exclusive

The Truckers Edge

Stiffer Edge for Sitting





For a better night's sleep and a chance to win one of several great prizes!

5546 Choctaw Drive
Baton Rouge, LA 70805
www.fleetmattress.com

866-973-1012

INFO@FLEETMATTRESS.COM

USE PROMO CODE (EDGE-20) TAKE AN EXTRA 20% OFF YOUR ENTIRE ORDER

The Circuit Rider

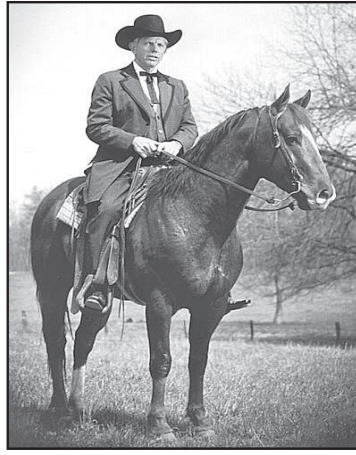

Robert E. Harris, "The Circuit Rider" was the nation's last practicing circuit riding preacher until his death in 2007. His ministry took him to numerous towns throughout western North Carolina as well as rest areas along I-40. His ministry and legacy continues through the Robert E. Harris Evangelistic Association, Inc., P. O. Box 67, Asheville, NC 28802.

AASHTO Supports President Trump's Message on Investing in Infrastructure

WASHINGTON – The American Association of State Highway and Transportation Officials applauds President Donald Trump for using his State of the Union address to call for greater investment in transportation infrastructure.

"The President's state of the Union Address is once again, making transportation infrastructure investment a top national priority," said Jim Tymon, AASHTO executive director. "Transportation has long been a bipartisan concern and this year, with the Administration's support a transportation bill can be that rare opportunity to bring members of Congress together from both sides of the aisle. AASHTO and its member state departments of transportation stand ready to work with the Administration and Congress on a national plan to shore up the Highway Trust Fund and make the investments needed to modernize our aging transportation infrastructure."

AIRLINES ARE HIRING – Get FAA approved hands on Aviation training. Financial aid for qualified students - Career placement assistance. Call Aviation Institute of Maintenance 877-818-0783

God Cares How Much We Care

We shed our tears from eyes that cannot see, so dark as we must walk, we cannot know we can only care. God rewards not for what we know, but how much we care.

Do you care for Him? He once said, "If you will confess me before men, I will confess you before the Father and the Holy Angels."

One of the most devastating things you can hear in this time is to hear someone say to you, "I don't care!" When you reach that position, especially in the terms of your spiritual life, you are in a sad state of affairs.

Jesus Christ cares. The Bible declares, "Casting all your cares upon him; for He careth for you."

When a caring person comes in contact with a caring God, they begin caring for others. We are our brother's keeper. The Christian has the responsibility of sending the gospel to the ends of the earth because he cares. They come to know this as we visit and give our encouraging words.

The Psalmist once wrote in a state of confusion, "No man cared for my soul." Jesus came to seek and save that which is lost. We have a caring God. Let us be caring people.

SEMI-DUMP CONTRACTORS START EARNING MORE IN 2019 BY USING THE NATION'S LARGEST TERMINAL NETWORK DEDICATED TO DUMP FREIGHT.

VISIT US AT M.A.T.S. BOOTH # 68032



U.S. BULK

TRANSPORT, Inc.

800-609-6611

usbulktransport.com

Build Your Business on a Strong Foundation!

We have the largest network of terminals and Logistics Offices in the Semi-Dump industry.

100% OWNER OPERATOR! NOT COMPETING WITH COMPANY TRUCKS
PAY 80% PER N/TTON + 100% OF THE FSC • GREAT FUEL DISCOUNTS • NO FORCED DISPATCH



TRI-STATE TRAILER SALES, INC.

Pittsburgh, PA....(412) 747-7777
Lancaster, PA.....(717) 569-4531
Hubbard, OH.....(330) 534-0082
Cincinnati, OH....(513) 874-4880

GO TO OUR WEBSITE www.tristatetrailer.com TO SEE OUR QUARTERLY SALES FLYER.



Qty 20- New Transcraft TL-2000 48'X102"
All Steel Apitong Floor, air ride sliding suspension, 12 sliding winches. 22.5 LP Steel Wheels.



(7) Heil 1040 SUPER SANDER,
41' x 96", Airride, Alum, stainless end-frames, 3 manways, curbside manifold, gravity, Stk# K371181 **\$67,950**

New Eager Beaver 20 ton Tag Trailers in stock - Call for special pricing Used Tags available too!!!!



(24) New Transcraft DTL-2100, 48'x102",
Air Ride, Steel, 11' upper deck, 37' main, 12 sliding winches, Stk# K3140811 **\$30,950**



New Manac Extendable Flatbeds 48'-80'x102" spring sliding suspension, 12 sliding winches.

CARGO CONTROL AND PARTS

Ankra & Kinedyne
4"x30' Flat Hook Strap
Part # KINE423021



Single \$11.00 ea.
Box of 10 \$9.95 ea.

RATCHET BINDER
Part# LDR-28-10



\$28.95

3/8X20FT GR70 CHAIN W/GRAB HOOKS
Part # 54320



\$41.50

5/16X20FT GR70 CHAIN W/GRAB HOOKS
Part # 54317



\$30.00

Ranger 3030 Brake Chamber
12.5" push-rod 24mo. warranty
Part # 1010460



\$36.75 (EA)

SILAPRENE ADHESIVE/SEALANT



SILM6325-GREY **\$10.00**
SILM6328-WHITE **\$10.00**

TOOLBOX
24"x24"x60" smooth double door



\$695.00 (flatbed)
\$675.00 (drop-deck)

HOLLAND LANDING GEAR
51k 4.5" shoe 17" travel



\$298.00











Daimler Trucks North America Delivers Its First Battery-Electric Commercial Truck to Penske Truck Leasing



Roger Nielsen, president and CEO of DTNA, ceremonially handed over the eM2 key to Brian Hard, president and CEO of Penske Truck Leasing, during an event in Carson, California.

LOS ANGELES, CA... Daimler Trucks North America (DTNA) delivered the first vehicle in its Freightliner Electric Innovation Fleet – a Freightliner eM2 – to Penske Truck Leasing, fulfilling its promise to put an electric commercial truck in customer hands in 2018. This delivery marks a key milestone in the real-world application of battery-electric commercial vehicles, as well as an important step towards emissions-free mobility.

The introduction of the eM2 into Penske's fleet is also a first

in DTNA's co-creation approach with customers as it co-develops technology to shape the future of transportation.

As the first step in its infrastructure deployment, Penske Truck Leasing will install 20 high-power charging stations across five of its California locations starting this month. Next year, Penske will put an additional nine medium-duty electric eM2 trucks and 10 heavy-duty eCascadia electric trucks into targeted service in California and the Pacific Northwest. Penske will place

the electric vehicles into service within its expansive logistics, truck leasing and truck rental fleets.

DTNA recently formed the Freightliner Electric Vehicle Council composed of 30 customers with strong use-cases for electric trucks, including Penske Truck Leasing, to further drive its sustainable transportation program. The company is working with the council members to ensure a holistic approach to launching electric trucks. Visit www.GoPenske.com to learn more.



JK Hackl Transportation Services

JK HACKL

"Driven to be the Best; Driven by the Best; for 27 years!"

(800)-669-2625
www.jkhackl.com

NOW HIRING
EXPERIENCED
FLATBED DRIVERS
AVERAGE PAY
\$.72/MILE

- Late Model Peterbilts
- Great Health Insurance
- Free Dental and Vision
- APU's *Pet and Rider Policy
- *PrePass Plus *Direct Deposit and much more!

Average Annual Driver Pay of \$75,000

go to www.jkhackl.com for complete details

\$5,000
sign-on
bonus



WE'RE TAKING TO THE ROAD WITH SOMETHING NEW

Howes
TESTED. TRUSTED. GUARANTEED. SINCE 1920.

Christmas in "Tire"land



Flynn's Commercial Tire Center in the Truckworld Complex, I-80 Exit 234, Hubbard, Ohio, used their imagination (and tires!) to create this incredible Christmas display this past December. - photo by Steve Pollock -

Shurhold's Moldaway Cleans The Natural Way



Made in the USA, scientifically formulated Moldaway contains no bleach or chlorine, so it's safe to use on colored vinyl, canvas, plastic, carpeting, interior and exterior cushions, car mats and wood. It removes mold, mildew, algae, dirt, and food and drink stains without scrubbing.

Using Moldaway is easy. Two tsp. of the powder is mixed thoroughly into a quart of warm water and will remain effective for 10 hours. The solution is then sponged or brushed onto a cool surface. After standing damp with the mixture for 10 minutes, it's rinsed with clean water. For extremely soiled areas, it can soak longer. A 12 oz. jar costs \$14.98.

Keeping a vehicle spot-free is a constant battle, with many owners resorting to harsh, toxic chemicals and lots of elbow grease. Moldaway from

Shurhold Industries is different. It's an oxygenated cleaner that's effective on a wide range of surfaces and removes stains the natural way.

Shurhold manufactures specialty care items and accessories to clean, polish and detail.

For more info call 800-962-6241; www.shurhold.com/auto.

PA COMMERCIAL REGISTRATION
START NEW COMMERCIAL ACCOUNTS
RENEW EXISTING APPORTIONED PLATES

We can HELP set up NEW Commercial Accounts with PennDOT!
Help with Mileage, 2290, DOT #, ICC, MC

193 City Ave. (Montgomery and Philadelphia County)
(610) 617-8850 ask for KIM
www.imperialautotags.com

The Imperial Agency, Inc.
state & service fees apply

Purchasing New Trucks?
We can do ALL your TITLE work!

PA Title Transfers
CDL Replacements and Renewals
Drivers License Restorations

Rocky's Truck Body Shop
"COLLISION IS OUR SPECIALTY"

- Painting • Insurance Claims • Major & Minor

I-80 + SR 62 + 7 Next to Truckworld
2325 N. Main St., Hubbard, Ohio (330) 534-7743
www.rockystruckbodyshop.net
e-mail: rockyrocks75@aol.com

BROKERED LOADS
For flats vans and specialized trailers.
Loads from Youngstown/Pittsburgh areas to all points.
★ TERMINAL PAY ★ PERMANENT LEASE ★

MERCER
"The Wright Place"
330-534-5677

7080 Truckworld Boulevard • Truckworld I-80 Exit 234 • Hubbard, Ohio

Make Every Minute Count.

CAT SCALE

WEIGH. PAY. GET GOING.

Would you like to add more time back into your day? The Weigh My Truck app will help you do just that. It is the fastest way to weigh. Weigh and pay all from your mobile device without leaving your cab, so you can get back on the road faster.

Find out more about how this app can revolutionize how you weigh your truck.

1-877-CAT-SCALE (228-7225)
catscale.com | weighmytruck.com

Now accepting:



Jones Performance Products, Inc.
Serving The Industry For Over Forty Years!
Ford Freightliner GMC International Kenworth

1-800-451-1600
www.jonesperformance.com

Mack Peterbilt Sterling Volvo Western Star

TRUCK RAZ
HDC ROD HOODS
KUSTOM MOLDED FIBERGLASS HOODZ
1 Joens Way, West Middlesex, PA 16159

Truck Hoods
Fenders
Bumpers
Headlights
Grilles
Cab Panes

Hans! of Cleveland **FREIGHTLINER**

Sales, Service and Parts
14520 Broadway Ave. Cleveland, OH 44125
216-581-0046
www.hansfreightliner.com

Your source for **GRAND ROCK** Exhaust Products

SHEA TRUCKING AND REPAIR
390 Mercer St. Clintonville PA
1/2 Mile off of I-80 exit 35, West on Rt. 208
LABOR RATE \$80/hr

- 24 hour road service • Major and minor repairs
- Authorized PA Inspections
- Alignment service - MD Alignment System

(814) 908-0083
M-F 7AM - 5PM Sat. - Sun by appointment

Peterbilt Recognizes Top Performing Dealers of 2018

SAN DIEGO, CA... Peterbilt Motors Company honored its top performing dealers with various awards at the 2019 Peterbilt Dealer Meeting. Dealers awarded for top performance in specific categories include:

- Red Oval Dealer of the Year; Hunter Peterbilt
- First Class Service Excellence Dealer of the Year; Valley Peterbilt
- Medium Duty Dealer of the Year; Rush Peterbilt Truck Centers
- MX Engine Dealer of the Year; The Larson Group Peterbilt
- Parts and Service Dealer of the Year; Rush Peterbilt Truck Centers
- TRP Dealer of the Year;

Peterbilt of Atlanta

The Best-in-Class Awards are based on a combination of Peterbilt's standard of excellence scores, financial performance, part and service performance and utilization of PACCAR training and programs. Dealerships receiving Best-in-Class Awards include:

- Allstate Peterbilt Group
- Camions Excellence Peterbilt
- Dobbs Peterbilt Group
- Jackson Group Peterbilt
- Peterbilt Manitoba
- Peterbilt of Atlanta
- Peterbilt Pacific Inc.
- Rush Peterbilt Truck Centers
- Stahl Peterbilt
- The Larson Group Peterbilt
- The Peterbilt Store

• Valley Peterbilt

"These award-winning dealers, and the dealer network as a whole, have invested heavily in adding and expanding facilities, hiring the best technicians, increasing hours of service and offering mobile service solutions that drive uptime and profitability for our customers," said Peterbilt's Director of Dealer Development, Peyton Harrell. "The Peterbilt dealer network is the fastest growing network in the United States and Canada, and has never been stronger."

For more information about Peterbilt, visit www.peterbilt.com.

Jacobs Launches Brake For Hino Motors' First US Class 8 Truck

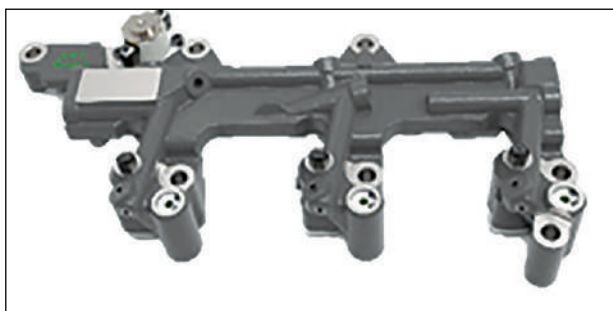

installed on all class XL7 and XL8 Series trucks. The engine brake for the A09 engine provides optimal braking performance which drivers have come to depend on. Some benefits include being fully integrated with the engine electronic control system and ABS, a two-stage brake operation of medium and high, and cruise control compatibility for greater driver control.

To learn more about the newly launched XL Series and the Jacobs Engine Brake performance, visit hino.com/hino-trucks-xl-series.html or jacobsvehiclesystems.com.

BLOOMFIELD, CT... Jacobs Vehicle Systems®, the world's leading manufacturer of diesel and natural gas engine retarding systems and valve actuation mechanisms, announces the launch of a compression release engine brake for the all-new 2020 Hino XL Series Truck.

The two companies partnered to design a high-performing compression release engine brake for Hino's first Class 7/8 commercial vehicle in North America.

The Jacobs Engine Brake® is currently available on Hino's A09 engine and comes factory



Truck Stopped? We'll Give You The "Green" Light

Get Up to \$15,000 on your commercial vehicle. Cover truck repairs, income taxes, insurance, IRP, new tires, or other working capital needs.

The last thing you need is to be sidelined. Big Rig Lending gets you funding in as little as 24 - 48 hours. No vehicle inspection required. That comes with fast approval, regardless of your credit history. Secure \$1,500 to \$15,000 for repairs, taxes, tires, or other working capital needs. Get the "Green Light" and you're good to go!

BR BIGRIG LENDING
We Lend. You Drive.

(888) 606-3007 9a - 8p EST M-F
BigRigLending.com Hablamos Español



EARN \$85,000 OR MORE A YEAR!

Driver Pay

- Includes
 - Variable per barrel pay
 - Reject load pay
 - Split load pay
 - Driver training pay
 - Deadhead & out of route mileage pay
 - Breakdown & wait time pay
 - Vacation pay
 - Paid time off
 - Sign on bonus
 - Employee referral bonus
 - Up to \$3,000 in safety bonuses each year

Benefits

- Medical/Dental/Vision
- Company paid life insurance
- Company paid short-term and long term disability
- 401 (k) w/ company match

OKLAHOMA

Panhandle: Perryton, Dumas, Woodward, Omega, Cushing, Amarillo

Central and Southern Oklahoma: Ardmore, Gainesville

Permian: Artesia, Hobbs, Carlsbad, Orla, Jal, Midland

Hiring in Western Texas, Oklahoma and New Mexico

See us at M.A.T.S. BOOTH #12268



833.239.4473 WWW.DRIVE4CP.COM

The 10th Anniversary - Eau Claire Big Rig Truck Show Celebration To Be Held on August 16, 17, 18



Bad Ass Trucking, LLC. - Dan Kaderabek, Cleveland, WI - 2nd Place 2018 Truckers' Choice Award; 1st Place 2018 Adults' Choice Award; 3rd Place 2018 Kids' Choice Award; 2nd Parade Spot - second highest bidder for UCP

Wayne Alberts, Justice, IL - 3rd Place 2018 Truckers' Choice Award (tie); 2nd Place 2018 Adults' Choice Award; 2nd Place 2018 Kids' Choice Award

J & M Norton Trucking - Mary Peterson Norton, Knapp, WI - 3rd Place 2018 Truckers' Choice Award (tie); 3rd Place 2018 Adults' Choice Award (tie); 1st Place 2018 Kids' Choice Award
Swen Transit - Joe Swendrynski, Wild Rose, WI - 3rd Place 2018 Truckers' Choice Award (tie)

Michael Holland, Spring, TX - 3rd Place 2018 Adults' Choice Award (tie)

Christenson Transport - Brad Christenson, Fountain City, WI - Lead Parade Spot - highest bidder for UCP

B. D. Schroeder Trucking - Bradley Schroeder, Warrens, WI - Third Parade Spot - third highest bidder for UCP

Glen Rice Transport - Glen Rice, New Smyrna Beach, FL - Volunteer Fire Fighters Recognition Award

Haas, Inc. Thorp, WI - Northern WI State Fairgrounds Recognition Award

Leonard's Express - Renee Dutter, Eau Claire, WI - OODA Recognition Award

The 10th Annual Eau Claire Big Rig Truck Show will be returning to the Northern Wisconsin State Fairgrounds (225 Edward St. Chippewa Falls, WI 54729). The Big Rig Truck Show will again have FREE admission to the public (parking \$5 per car Friday and Saturday, free parking Sunday). Not only will some of the country's top show trucks with customized interiors, unique light displays, beautiful murals, brilliant chrome work and unique modifications will be showcased, but so will working show trucks that will be back on the road Monday morning. A large variety of additional vehicles will also be displayed; antique, non-working, custom

creations, fire trucks, tow trucks, construction vehicles, tractors of all sizes, SWAT, law enforcement and military vehicles will be in attendance.

Highlights and attractions for this coming year's Anniversary Show include the Saturday Night Light Parade through Chippewa Falls (parade map available online).

A Demolition Derby will be held Saturday. More information about this new and exciting event can be found online at ECTruckShow.com in the upcoming weeks.

Many outside and inside exhibitors will be demonstrating and selling a wide variety of products. Exhibit Hall A is where guests can find the

Allstate Peterbilt Kids Zone, with free professional face painting and a coloring contest. River States Truck & Trailer will again be hosting free semi rides on Sunday. There will be food available from many local food trucks and a beer garden for the adults.

Live music all weekend in the beer garden courtesy of River States Truck & Trailer. Rich Schroeder will be performing during the day and Austin Fire will be on stage in the evenings. Chainsaw artist Leesa Syrczuk will be in action throughout the weekend. A representative from State Patrol will be available to answer any questions about the rules and regulations of the road. Many more fun family

activities are in the works.

Registered drivers can relax and enjoy all that the show has to offer. 1st, 2nd, and 3rd place People's Choice, Kids' Choice and Truckers' Choice awards will be presented to participating drivers along with thousands of dollars in prizes on Sunday.

The Eau Claire Big Rig Truck Show is a community event that brings together people of all ages, giving them the opportunity to see the world of trucking. The truck show works in conjunction with following local non-profit groups: United Cerebral Palsy of West Central Wisconsin and the Hands Foundation helping homeless veterans and others in need

who will be collecting clothing and toiletries. A complete list of needed items and donation sites can be found online.

Check out ECTruckShow.com for more about the show, future announcements, show hours, sponsorship opportunities, exhibitors, and other up-to-date information. To become involved or if you have any questions please feel free to call 715-832-6666. Hope to see you at the show on August 16, 17, 18, 2019!

2018 Eau Claire Big Rig Truck Show Winners List
Brent Hartwig Trucking, Inc. - Brent Hartwig, Medford, WI - 1st Place 2018 Truckers' Choice Award



— MARCH 28th to 30th 2019 —

COME VISIT US AT

MID AMERICA TRUCKING SHOW
KENTUCKY EXPO CENTER, LOUISVILLE — BOOTH 34125



Eastern Sales Office 877 466 2622
Western Sales Office 833 445 0989

manac.com
facebook.com/manacinc

9th Annual EAU CLAIRE BIG RIG TRUCK SHOW



All Photos courtesy of Eau Claire Big Rig Truck Show

For complete photo coverage go to www.movinout.com

Cooper Tire Launches New Roadmaster RM351 HD Mixed Service Drive Tire



FINDLAY, OH... Cooper Tire has announced the addition of the Roadmaster RM351 HD tire to its commercial tire lineup. Engineered for mixed-service applications such as construction, logging and mining operations, the tire is designed for both on- and off-road driving, and comes in two sizes: 11R22.5 and 11R24.5, in load range H.

The Roadmaster RM351 HD is a full inch wider than its predecessor, the RM300 HH, with a 20 percent larger footprint. Coupled with its deep 32/32nds tread depth, it provides up to 25 percent more miles to removal – depending upon the application. “That’s a big step forward in tire performance for our Roadmaster customers,” said Gary Schroeder, Executive Director of Cooper’s Global Truck and Bus Tire Business. “By going wider, we spread the weight over the tire to gain better mileage, while also improving traction. It’s a win-win.”

To help ensure long tire life, tie bars between the outside lug and the shoulder, along with shoulder grooves that are linked and interlocked, help ward off tire squirm and irregular wear. The sidewall

is extra thick with a curb bar protector to help protect the casing from cuts and scrubbing.

For traction and long-life performance, the tire features five lugs that have an open pattern to minimize stone holding while enhancing traction. Stone ejector ledges, coupled with angled grooves, also help prevent stone drilling. “That’s a key feature of the tire as it will be used off-road where sharp stones can be a tire’s worst enemy if they’re allowed to drill into the casing. The way we designed this tire helps preserve the casing for multiple retreads,” Schroeder added.

The Roadmaster RM351 HD’s casing itself is extremely robust, with four-belt steel design construction. Cooper provides a six-year, two retread warranty on the RM351 HD. “The casing we’ve developed for this tire, along with the warranty, provide life and cost efficiency beyond the original tread,” said Schroeder.

For more information on Cooper, visit www.coopertire.com, www.facebook.com/coopertire or www.twitter.com/coopertire.

ATA Backs President Trump’s Calls for Infrastructure and Trade Action

Arlington, VA... Following the recent State of the Union address, American Trucking Associations’ President and CEO Chris Spear applauded President Donald Trump for his proactive calls to address the nation’s aging infrastructure and modernize our trade relationships with our North American neighbors.

“Tonight President Trump called for a national, bipartisan effort to restore our country’s declining infrastructure -- and America’s truckers are answering that call,” Spear said. “A win on this issue will require real investment, not budgetary gimmicks as tried in years past. That is why America’s truckers, along with a broad coalition of the business community, have pledged our financial commitment to making this national priority a reality.

“Decades of failed leadership in Washington have led us to this point, which is why we commend the President for seizing this opportunity to bring all sides together to forge a common path forward. Restoring our national infrastructure to greatness will further ignite our economy, make us more competitive abroad, and give Americans more time to spend with family and less time stuck in traffic.”

Spear continued to urge Congress to move quickly on the new United States-Mexico-Canada Agreement.

**ENGINEERED
TO HANDLE
EVERYTHING
ALONG THE WAY.**



LONG HAUL / REGIONAL
MIXED SERVICES / PICK-UP & DELIVERY

Roadmaster has commercial tires for every application. Long Haul. Regional. Mixed Services. Pick-up and Delivery. Tires engineered in America by Cooper Tire for North American roads. Wherever your journey takes you, we have the tires to get you there.

Learn more at RoadmasterTires.com.
Contact us at roadmasterinfo@coopertire.com.

ELLET RADIATOR SERVICE INC.

2802 Albrecht Ave. Akron, Ohio (Minutes from I-76)

330-784-8226

www.ElletRadiator.com

SPECIALISTS IN COMMERCIAL AND HEAVY EQUIPMENT RADIATORS.

New in Stock

Radiators • Charge Air Coolers
AC Condensers • EGR Coolers • DPF Filters

NOW TESTING & CLEANING DIESEL PARTICULATE FILTERS

Cleaning • Repairing • Recoring
Fuel Tank Repair • Aluminum & Steel Welding

Century Finance



SINKING!!!

Call: 888-684-7195

Need Cash Today? Factoring It's Easy!

www.centuryfinance.com

New Aftermarket Friction Joins Bendix Brake Lineup



When it comes to aftermarket air disc brake (ADB) pad replacement—no matter where you are in a vehicle's life cycle – quality, value, performance, and choice are critical. That's why Bendix Spicer Foundation Brake LLC (BSFB) is adding the new Bendix® BA235 air disc brake pad kit to its robust aftermarket portfolio.

The right selection for both truck/tractor and trailer ADB applications, the BA235 pad provides a lower-cost option for pad replacement while retaining the performance, warranty, and post-sales support expected of North America's leader in commercial vehicle air disc brakes. The BA235 aftermarket kit – best suited for a second or third vehicle owner—is available through authorized Bendix® dealerships and aftermarket distributors starting January 2019.

As part of their expanded air disc brake pad portfolio, Bendix also offers the BX276 genuine OEM replacement pad. The

long-life BX276 pad is suitable for all applications and provides more wearable volume and an improved wear rate. For severe duty brake applications such as refuse and school bus, Bendix offers the BX283 pad. All of these Bendix ADB pads meet FMVSS-121 requirements and the current EPA Copper-Free Brake Initiative requirements.

"When Bendix says its aftermarket pad friction meets FMVSS-121 requirements, we mean it. We don't cut corners to take cost out, specifically when it comes to safety. In today's marketplace, we know vehicle operators have options when it comes to replacement pad choices for our ADB22X™ brake, but we urge owners to be wary of the reduced performance on a number of these aftermarket choices," Keith McComsey, BSFB director of marketing and customer solutions, Wheel-End said. "Our testing shows that stopping distance performance can be severely

impacted – adding up to 75 feet, or roughly the equivalent of five car lengths – when non-Bendix pads are used. While also increasing the potential for rear-end collisions due to extended stopping distance, inferior aftermarket pads may also increase the risk of vehicle roll-aways, since many of them do not meet the FMVSS-121 park-hold requirements. Some of these pads have significantly reduced capability, rating at only 40 percent of the requirement."

When it comes to wear performance, Bendix ADB pads are designed to provide long pad and rotor life. The BA235 pad has good wear properties and provides consistent rotor wear while meeting Bendix's rotor stress cracking requirements.

For more information about Bendix air disc brake pads, call 1-800-AIR-BRAKE or visit www.foundationbrakes.com.

CUMBERLAND TRUCK SERVICE
LUBE • REPAIRS • TIRES

Located at **FLYING J Travel Center**

HARRISBURG, PA I-81 EXIT 77

855-265-4160

<p>SPECIALIZING IN</p> <ul style="list-style-type: none"> • Express Lube • Tire Sales • Wheel Alignment • Wheel Balancing • Trailer Washouts • Truck Maintenance • Preventative Maintenance • Roadside Repair 	<p>REPAIRS</p> <ul style="list-style-type: none"> • Truck • Trailer • Tire • Electrical • HVAC • Airline • Brakes • Wheel End • Suspension • FEP DOT Inspections
--	---

CUMBERLAND TRUCK SERVICE
LUBE • REPAIRS • TIRES

I-81 PA EXIT 1, **HAGERSTOWN MD.**
RT. 163 EAST TO RT 11 SOUTH
1/2 MILE ON LEFT

800-864-8164 www.CumberlandTruck.com

<p>SPECIALIZING IN</p> <ul style="list-style-type: none"> • Express Lube • Tire Sales • Wheel Alignment • Wheel Balancing • Truck Maintenance • Preventative Maintenance • Roadside Repair • Fault Code Diagnostics 	<p>REPAIRS</p> <ul style="list-style-type: none"> • Truck • Trailer • Tire • Electrical • HVAC • Airline • Brakes • Wheel End • Suspension • FEP DOT Inspections
--	---

Cargill™
Meat Logistics Solutions, Inc.

NEW Dedicated Refrigerated Lanes

We offer year round freight, direct from the shipper, great rates, avg 2,500 miles/wk, great home time

- Expanding our Reefer Fleet
- Priority loads from Cargill plants
- 100% owner-operator fleet
- Sign-On bonus
- Settlements processed twice weekly
- Year round freight available
- Fleet owners welcome
- Top solo's grossing 300K

New \$5,000 Bonus

Dodge City, KS
Springdale, AR
Frona, TX • Schuyler, NE

800-835-3119 and cmlsrecruiting@Cargill.com

SEE US AT M.A.T.S. Booth # 19208

The Fuel Mileage Doctor inc.

WITH BULLY DOG

BIG RIG PRODUCTS

THAT RAISE THE BAR ON QUALITY

TUNERS

- Fuel mileage tested in real time with Taylor fuel monitoring equipment
- Tested for your engine's safety
- Power tuning that excites

MANIFOLDS

- Flow tested for maximum efficiency
- Proven mileage gains
- Spool turbo quicker

GT Tuner- was \$2,800.00 NOW ONLY \$1,899.00

EMC Tuner- was \$1,850.00 NOW ONLY \$999.00

Kevin Campbell
Kevin@fuelmileagedr.com
717-320-2259 | McAlisterville, PA 17049
FUELMILEAGEDR.COM

Visit US TODAY

Volvo Trucks to Offer Versatile Workstation for VNL 740, 760 and VNX 740 Models



This new workstation setup is designed to improve driver productivity, comfort and overall convenience.

Volvo Trucks adds an ergonomically advanced workstation to its VNL 760, 740 and VNX 740 models, providing a flexible living environment for thousands of drivers who make their homes on the road. Designed to improve driver productivity, comfort and overall convenience, the upgrade is now available for order.

"This advanced workstation is the latest example of the emphasis Volvo Trucks has placed on enhancing driver comfort and driver productivity," said Allison Athey, product

marketing manager at Volvo Trucks North America. "The ability to create an exceptional all-in-one living space and working environment is essential to attracting and keeping drivers."

Each year, truck drivers spend thousands of hours in their cabs driving, living and keeping the economy going. The new workstation provides a relaxing, versatile living space for work and rest to enhance driver productivity.

This workstation was developed as a result of

rigorous testing and input from Volvo customers and drivers. It features ergonomic advancements that allow drivers to enjoy the comforts of home while on the road. The workstation transforms from a sitting area and table for relaxing, eating and catching up on work, then lowers as a base for seating cushions that unfold into a bed. Additional enhancements include an angled table for easy seating; a 103-degree cushion seat angle to improve seating comfort; and connected cushions that

can be easily secured to allow for adequate rest.

The workstation is a prominent feature in the cab, giving drivers flexibility to personalize their living space while on the road. With various configuration possibilities, solo drivers may prefer to leave the table set-up and sleep in the top bunk, while team drivers may choose to collapse the table for access to both bunk beds. The workstation also allows space for storage inside the bottom bunk bases.

Ideal for owner/operators and fleet drivers on the road

for extended periods of time, the workstation has been shown to help boost resale value for customers. Previously successful on the

VNL 670 model, the enhanced workstation for the VNL 760, 740 and VNX 740 models enters production in February 2019.



HURRICANE TRUCK WASH

1/4 mile south of I-80 exit 78 Brookville PA
OPEN 24 HRS/7 DAYS
 • Brush Washes • Trailer Washouts M-F 9AM - 5PM
 • Self Serve Washes 24/7 After Regular Hours • Fleet Accounts Welcome
814.849.6899 www.hurricanetruckwash.com



BYOD

Be Your Own Boss!

This is what FREE authorities feel like.

Free MC/DOT BOC-3. No Application Fee.
 No Processing Fee. No Factoring Contract.

No one processes more authorities than we do.



877-496-4520 | freeauthority.com



GET OUR 2019 FREE CATALOG
 CALL 603-224-7370
 Go To WWW.BERUBES.COM
 OR SCAN WITH YOUR SMART PHONE



WE HAVE A MILLION DOLLAR INVENTORY AND A VERY KNOWLEDGEABLE STAFF. THAT MEANS YOU GET THE RIGHT STUFF RIGHT AWAY.



Season Closeout!



ESPAR Airtronic D2 Bunk Heater
 Special Pricing
\$895.00
 Complete Kit Including Controller and Pickup Tubes!

CERNI INTERNATIONAL
 MEANS TRUCKS!

5751 Cerni Place (RT 46 & I-80 exit 223) Youngstown, Ohio 44515
800-686-5432
 Cerni International North Coast Inc. 431 Richmond St. Painesville, Ohio 44077
800-362-1470

TO LEARN MORE LOG ONTO www.bunkheaters.com

EQUIPPING YOUR TRUCK TO DO MORE

At Beiler Hydraulics, truck systems are what we do. By using our industry experience in wetlines, we can sell or install a system that will expand what your truck can haul, giving you more opportunity to keep your truck on the road and profitable.

WETLINE KITS FOR WALKING FLOORS DUMP TRAILERS LOWBOYS DUAL SYSTEMS PROPANE BLOWER SYSTEMS



Beiler HYDRAULICS

717.656.4878
322 E. MAIN STREET LEOLA, PA 17540
WWW.BEILERHYDRAULICS.COM

Owner Operators Drive Less - Earn More!

SEE US AT M.A.T.S. BOOTH #61029

Clark Transfer

Let's Get the Show on the Road™

Live Entertainment Transportation Family owned and operated since 1949

800-440-6361

www.clarktransfer.com

Find Us On Facebook

"You be seeing more O' the green when you stop by the Triple K"

24 HOUR TOWING & ROAD SERVICE FULL SERVICE MULTI-BAY SHOPS 717-635-7500

WWW.TRIPLEKFLEET.COM



The mobile Spindle Replacement Specialists...



Triple K Fleet Services

Of Central PA The Mobile Spindle Replacement Specialists...

(717) 395-5730

1/4 THE COST OF A NEW HOUSING AND LESS DOWN TIME!

\$100 OFF your next spindle job with this ad or coupon Exp. 3/31/19

We now do Spider Plates!!



MOVIN' OUT

Our 44th year

**VISIT US
AT THE
MID-AMERICA
TRUCKING
SHOW**

BOOTH #12229

MOVIN'OUT.COM

MCCOLLISTER'S AUTO TRANSPORT FLEET EXPANSION



MCCOLLISTER'S ENCLOSED AUTO TRANSPORT FLEET IS CONTINUING TO GROW DUE TO OUR CLIENTS AND OUR TALENTED DRIVERS.

**DRIVER
RETENTION
PROGRAM**
FIRST YEAR \$3,500
2ND \$5000
3RD \$7000

OPPORTUNITIES AVAILABLE
FOR OWNER OPERATORS &
COMPANY DRIVERS.

NEW TRAILERS COMING IN
MONTHLY.

FOR MORE INFORMATION CALL:

JOE CSIK (EAST)
1-800-257-9595 EXT. 9490

PAUL (WEST)
1-800-257-9595 EXT. 1041

WWW.MCCOLLISTERS.COM



Available in bottles, 5 gallon pails, 55 gallon drums and 330 gallon totes.



FPPF Chemical Company
Buffalo, New York
1-800-735-3773

The Premium Fuel Additive Company

www.fppf.com

ULSD & Biodiesel FUEL PROBLEMS? FPPF has the Solutions.

SEE US AT
**M.A.T.S.
BOOTH
#10096**



FPPF PRODUCT BENEFITS:

- Cleans Injectors
- Eliminates Water
- Dramatically Improves Fuel Lubricity (ASTM6079 HFRR)
- Increases Cetane for effortless cold starts
- Stabilizes Fuel
- Improves Combustion
- Kills Fuel Bacteria
- Improves Fuel Economy
- Increases Power
- Unsurpassed Antigel Protection

(All FPPF additives are compliant with EPA ultra low sulfur content requirements.)

FPPF makes your fuel better!

TCA Honors Highway Angels



Professional Truck Driver Helps Saves Woman, Dog After Horrific Crash

Alexandria, Virginia: Brian Snell of Merrimack, New Hampshire, a professional truck driver for Pottle's Transportation of Hermon, Maine, has been named a Highway Angel by the Truckload Carriers Association (TCA). He is being recognized for rescuing a trapped motorist from a crushed vehicle moments before the car caught ablaze and saving a dog who was trapped in second vehicle after owner succumbed to injuries.

On June 8, 2018, Brian Snell was driving along 495 in Westward, MA when he encountered a woman heading the wrong way on the freeway. Just as Brian realized what was happening, the woman in the oncoming car spun out directly in front of Brian's truck. Brian quickly jumped to action. He came to a stop to block the road and protect the woman's car because she did not have her lights on. He then went over and starting trying to resuscitate the woman who he noticed was unconscious.

"I was a paramedic for such a long time that it was second nature for me to start to work on her," recalls Brian.

Just then, he felt that something wasn't right. He noticed that her engine was on fire! Acting swiftly, Brian grabbed his fire extinguisher and began extinguishing the flames. He then heard someone yelling that they couldn't get in to the vehicle, and that's when Brian realized that the female motorist had hit another car head on before coming to a halt.

Brian ran over and checked the man's pulse and vitals in the other vehicle, and sadly realized the man has succumbed to his injuries. "The car had crushed him," recalls Brian. "So as hard as it was to leave his side, I ran back to the woman to continue working on her."

For what felt like hours later, an ambulance and emergency personnel arrived. Brian helped remove the doors to the woman's crushed car as she drifted into consciousness. The crew rushed her to the hospital as Brian went back to the deceased man's car to discover there was a dog inside. "We got the dog to a vet and they were able to save and return the dog to the man's family, which they were very happy about," said Brian. He stayed at the accident scene to help extract the man from his vehicle and to load the crushed cars on a tow truck.

Brian later learned that the female motorist was heavily intoxicated and was charged with vehicular homicide. "It's devastating to know she killed an innocent man," he said. "But I also know she will unfortunately now have to pay for that the rest of her life."

This isn't the first time Brian has completed a heroic deed. Upon exiting the Marine Corps in 1992, he worked for many years as a paramedic and was a rescue worker on September 11, 2001 at Ground Zero. Unfortunately he lost a lung during those recoveries and could no

longer serve in law enforcement. As he still had the urge to help others, Brian started a volunteer fire department as well as started his career in the trucking industry.

"I'm like a magnet to this kind of thing. I've probably stopped at eight different accidents since I helped save this woman last Summer, he shared. "It's either a blessing or a curse that I'm around often for this kind of thing. Unfortunately the world is getting crazier out here, so I'm always alert and help when I'm needed. Never thought I needed an award or recognition for that," said Brian, graciously.

For his willingness to assist a fellow citizen, TCA has presented Snell with a certificate, patch, lapel pin, and truck decals. Pottle's Transportation also received a certificate acknowledging their driver as a Highway Angel.



Challenger Motor Freight, Inc. Driver Named TCA Highway Angel for Assisting Motorist from Overturned Car

Alexandria, VA... Terry McKnight of Aylmer, Ontario a professional truck driver for Challenger Motor Freight, Inc. of Cambridge, Ontario has been named a Highway Angel by the Truckload Carriers Association (TCA). He is being recognized for assisting a motorist after a high-speed crash.

Rush hour traffic was starting to build on I-75 in Cincinnati that day in October and Terry McKnight, a dedicated run driver for Challenger Motor Freight, was on his way to Lebanon, Kentucky. He was in the middle lane of the three-lane road when he saw a car enter the highway at a high rate of speed—McKnight figures 70 mph—cut across the slow lane to the middle lane and then try to squeeze in between two cars in the fast lane.

"She didn't give herself enough room to make the lane change," McKnight said of the driver, "and hit the rear of the car in front of her, making it spin around. When it stopped, it was facing oncoming traffic."

The collision caused the speeding vehicle to flip upside down and slide, on its roof, down the middle of the road. McKnight followed the driver, stopping behind where the overturned car came to rest, and positioned his truck to prevent other vehicles from hitting the car. McKnight rushed over to help the motorist as she was trying to crawl out of her badly-damaged car. He called 911 and stayed at the scene until police arrived and took his statement. One of the officers thanked McKnight for stopping to help—as it turned

out he was the only one who stopped that day. From start to finish, he says he was there just 22 minutes.

"Everybody's in a hurry," said McKnight. "I was just in the

right place at the right time. I made the decision to stop and block traffic from hitting her car. I didn't want to see her get hurt. I would do it again if I had to."



Jared Flach Retrieves Trapped Motorist from Burning Vehicle, Injured Second Motorist Near Scene of Accident

Alexandria, VA... Jared Flach of Theodore, Alabama, a professional truck driver for Groendyke Transport of Enid, Oklahoma, has been named a Highway Angel by the Truckload Carriers Association (TCA). He is being recognized for retrieving a trapped motorist from a burning car and assisting an unconscious motorist near scene of accident.

It happened at 2 a.m. on November 4 as Flach was heading east coming out of the weigh station in Pensacola, Florida with a full load. That's

when he saw it—a car on fire in the middle of Interstate 10. Other cars had pulled over onto the shoulder. Reacting quickly, Flach stopped his truck a safe distance from the scene, jumped out of the cab, and asked bystanders what had happened: An eastbound car had struck the rear of an 18-wheeler, spun around and was now facing oncoming traffic.

"People were afraid to approach the car because there was a fire underneath the hood and they were afraid of an explosion," shared Flach.

However, he could see there was someone still in the car. He approached and found a male driver, conscious but in pain, trapped by the steering wheel which was jammed between the man's ribs and belt. Flach knew he needed to buy some time to get the man out, so he ran back to his truck, grabbed his fire extinguisher and attacked the flames. Without a moment spare, another truck driver handed his fire extinguisher to Flach as soon as his ran empty. A man who had pulled his RV over to assist discharged his extinguisher as Flach went back to help the driver who now told him he could feel the heat at his feet but couldn't move his legs.

The engine compartment was now on fire. Flach knew the motorist likely had broken ribs and legs but had to take action to get him out of the vehicle. Another driver helped Flach pull the man from the vehicle as flames broke through the firewall and began entering the cab at the man's feet. They laid him on the grassy shoulder and then rushed back to the car to see if anyone else was inside. It was then that they discovered a woman lying outside the vehicle.

"We didn't know if she got out on her own or if she'd been ejected," Flach says. "She wasn't very responsive." The two men moved her a safe distance away from the burning car and waited for rescue vehicles to arrive.

Flach says this is not the first time he's encountered this kind of situation: He used to be a fire fighter and EMT. Thanks to his training, arriving at the scene when he did and following his instincts to rush in and help when others were frozen with fear, Jared Flach likely saved two lives that day.

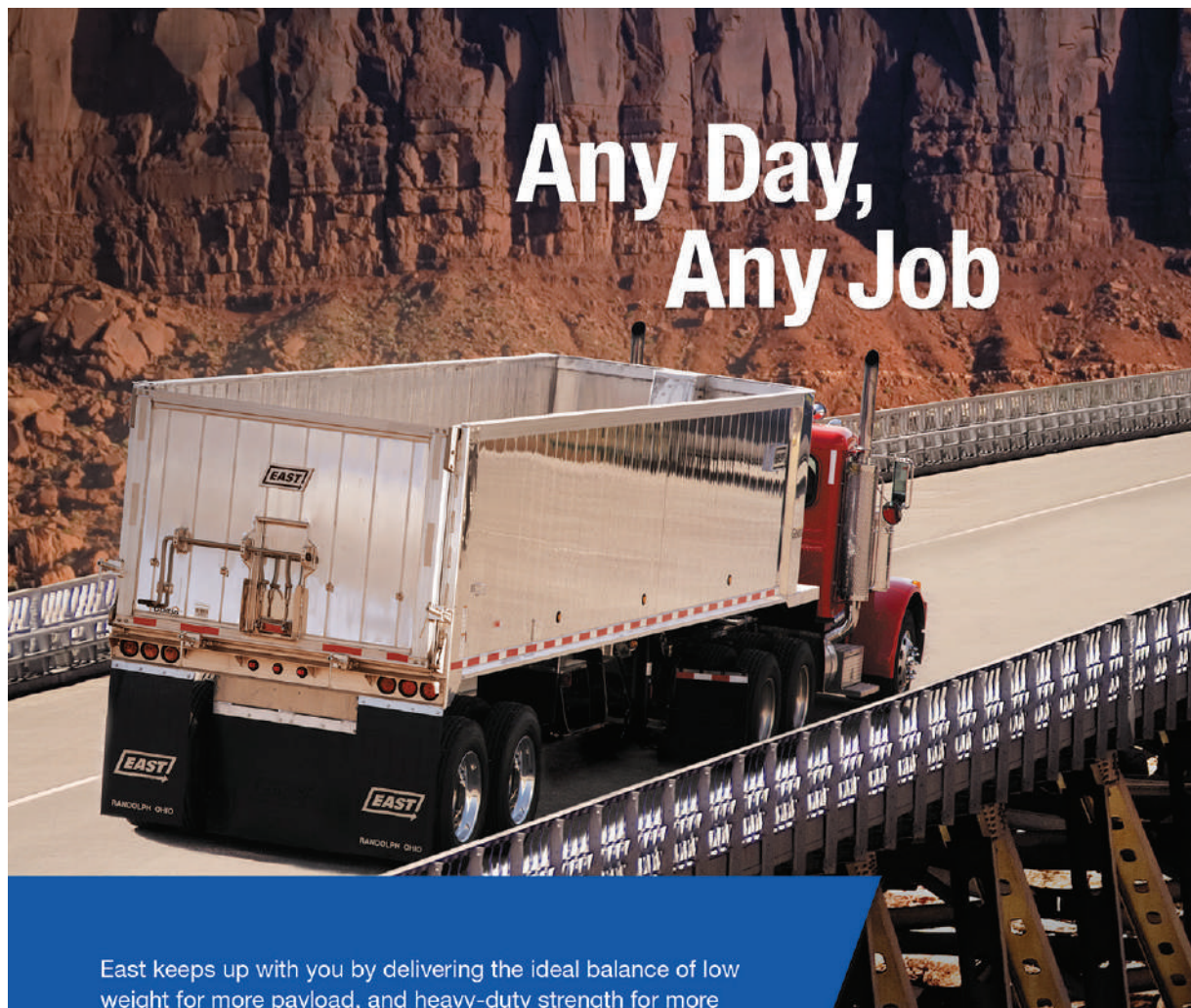

East keeps up with you by delivering the ideal balance of low weight for more payload, and heavy-duty strength for more durability with our frame and frameless dump trailers. The East Genesis® smooth-side and traditional external post dump trailers' strength and high load ratings give you versatile and flexible load options. East trailers cost less to maintain and repair, and they deliver maximum return on your investment. East keeps up with you — any day, any job.



EastMfg.com • 888-405-3278



YOUNGSTOWN KENWORTH 7255 Hubbard-Masury Road
Hubbard, Ohio
I-80 Exit 234
800-321-2056

150+ TRUCKS IN STOCK & SHORT LEAD TIMES

**CLASS 8 - T680, T800, T880, W990 & W900L
MEDIUM DUTY - K & T SERIES AVAILABLE**



- 110 & 120 BBL WATER TRUCKS - DUE IN SOON
- HEAVY HAUL 4 AXLE TRACTORS - IN STOCK
- SPECIALIZED CAB & CHASSIS - IN STOCK
- W900L STUDIO SLEEPER SPECIALISTS

Dave Claypool c# 330-301-2335
Mike Byers c# 330-360-2879

For a complete inventory go to
www.youngstownkenworth.com

DIDJA KNOW - COPS AND TURNPIKES



Traveling east across the New York Thruway several miles from Newburgh, I saw a state police cruiser stopped on the right-side shoulder. The blue lights were flashing and, as always, I eased over to the left lane, watching intently for the officer. I didn't see one, and there was no one else around either. Suddenly very concerned, realizing the squad car was unmanned, I pulled over a hundred feet in front of the cruiser. All kinds of images ran through my mind as I ran back down the shoulder. Was the officer hurt? Kidnapped? Dead? I tried to be careful, as I approached the cruiser, not to step on possible evidence or miss anything that might have been in the ditch. There was nothing. Peering into the car, I could clearly see it was unoccupied, and the engine was still running. Looking past the unit, and across the field, I could nothing amiss there either.

With a sense of dread, I looked under the car, and was relieved to see just daylight. But the mystery was getting to me. What could possibly have happened? Why was the cruiser running? My good sense was telling me to leave, but curiosity won the war of conscience.

Suddenly I spied a turnpike authority truck approaching, and decided to flag it down. The crew in the truck became concerned as I was, but they had something I didn't—a radio. Calling their office on the open state frequency, they broadcast our worries across the entire district, and within a minute there was a county sheriff's deputy on the scene.

But something was out of place with him too, because he had a passenger wearing a blue state police uniform, with a contrasting red face. It was, after all, his squad car I had painstakingly worried about. It seems he had made a routine traffic stop, but then locked himself out of his own cruiser.

The good news was, he had a portable radio, so he called for a sheriff's unit, who picked him up and transported the trooper to the local state police barracks. There he was able to get a set of spare keys and, without anyone noticing, return to the scene of his lockout. No one noticed, that is, until his predicament was broadcast all across the state radio network.

We all had a laugh at his expense, then parted ways with wry smiles and firm handshakes.

Years later, hauling an over-size load, I set off the over-height alarm on a Kansas turnpike. I chose to ignore it. The Kansas Highway Patrol did not, pulling me over just a few minutes later. Polite but firm, the trooper checked my load height and pronounced it illegal.

But he was fair and asked if my truck was capable climbing the embankment next to an overpass. If it is, he said, you can get take that county road and not get a fine. It is capable, I assured him, but then asked this question: where does that county road go? His polite but firm answer was direct and to the point;

"I don't know, and I don't care!" he said.

Law enforcement is a challenging and dangerous profession even on the best of days. Yet they're on the job, (and shoulder of a turnpike), doing a job most of us can't. What we can do is our part to keep them safe. I'm glad to be a part of moments that!

THOUGHT FOR THE DAY: Do dogs see police canines and think, "Oh no, it's the cops!"

You can reach Roger at rog-erclark437@gmail.com

PROFESSIONAL OTR DRIVERS

**Love Trucking but want to be home every night?
Come to work for American Bulk Commodities**

Now Hiring Near

Alabama: Brewton, Calera, Decatur and Mobile
Ohio: Barnesville, Canton, Cleveland, Dayton, Mansfield, Marietta, Toledo and Youngstown
Pennsylvania: Portersville **South Carolina:** Gaston

Must be at least 23 with 6 months Tractor Trailer experience - Will train to do Dump Work

OWNER/OPERATORS WITH OPERATING AUTHORITY

Now leasing in the Cleveland Ohio area for local and regional work.

Semi End Dumps • Municipal Solid Waste • Roll-offs • With or Without a Trailer • Percentage Pay
We will assist you in obtaining your own operating authority



Call 800-262-9365
American Bulk Commodities

"Leading The Way"



R&J Trucking Inc. • John Brown Trucking • Southern Haulers

Shell Rotella® HD Grease Premium Heavy-Duty Grease



high quality, multipurpose, extreme-pressure grease based on a blend of high viscosity index mineral oils and a lithium hydroxystearate soap thickener that contains extreme-pressure and other additives to enhance performance in a wide range of applications. Shell Rotella® ET Grease is designed for the lubrication of most on and off-road vehicles and equipment. It is a lithium complex grease based on high viscosity mineral oils and polymers for improved adhesion and retention on exposed surfaces such as fifth-wheel plate pivots, wheel bearings, springs, trailers, open pivot joints and weather exposed equipment. The grease is extremely tacky, water resistant, and suitable for high temperatures. Shell Rotella ET Grease contains antioxidants, extreme pressure and wear preventive additives, and rust inhibitors for long service life and corrosion protection.

Performance, Features & Benefits:

- Wear protection in high temperature and exposed conditions
- Corrosion protection
- Resistance to water wash out and wash off
- Bearing lubrication including

- wheel bearings
- General chassis lubrication of vehicles
- Use in industrial, farm, construction, and yard equipment

Shell Rotella® HD Grease is a premium multi-purpose grease for on and off-road vehicle applications with the versatility for industrial equipment use. It contains our latest performance additives to provide excellent high temperature oxidation performance, corrosion resistance and extreme pressure and anti-wear protection. Shell Rotella HD Grease is especially suitable for bearings operating at high temperature and under load such as disk brake equipped wheel bearings. Shell Rotella® SD Grease Special Duty Moly Grease Shell Rotella® SD Grease is a high-performance, high temperature grease for vehicle and equipment lubrication. Formulated with moly solid lubricant (molybdenum disulfide), Shell Rotella SD Grease is designed for lubrication of demanding applications in vehicles and equipment that are subjected to high shock loads where rapid starts and stops may occur, impacting such things as chassis points, sliding pins, trailer hitches, and axle splines.

Shell Rotella® MP Grease-Multi-Purpose Lithium Grease Shell Rotella® MP Grease is designed for multipurpose grease lubrication of on and off-road vehicles and equipment for general chassis, springs, pivot points, low speed bearings (not disk brake wheel bearings), and equipment such as mowers, trailers, lifts, and loader buckets. Shell Rotella MP Grease is a

"THE HOT ONES"
MADE IN THE USA

EVERBLADES
HEATED WIPER BLADES
www.everblades.com

HUNTER TRUCK
www.huntertruck.com

20 LOCATIONS
Pennsylvania - New York
New Jersey - West Virginia

EXTREME TRAILERS
Now Available at **TRAILER ONE INC.**
1-800-340-4742

6378 Norwalk Rd. Medina, OH www.TrailerOne.com

TRAILER ONE

"I like the over 1,000 lbs. lighter tare weight of the Extreme Trailer along with other features like the low rise deck. There is about 12" of rear adjustment using the airbags. I can also level the deck using the airbags. The lower deck height keeps the center of gravity lower and allows me to haul taller loads. My trailer has a front lift axle and is California compliant. The air lines are placed for easy access and the Stainless tool boxes and rear Hollywood lights look great"

-Mike Tarantino- owner of Kickin Dust Logistics from Galt Ca. leased to Gulf Stream Transportation out of Estacada Or.

JLE Industries

OTR FLATBED DRIVERS

START AT .50/.55 PER MILE
+\$5,000 SIGN ON BONUS

GET YOU MOVIN', GET YOU PAID, GET YOU HOME!
877 - 959 - 6915
www.jleindustries.com

Find us on Facebook

STEP UP TO FIRST CLASS!
JOIN THE ELITE FLEET!

\$1,000 ORIENTATION PAY
AND
NEW GUARANTEED PAY PROGRAM
CALL 888-219-8042 TO LEARN MORE!

SMITHDRIVERS.COM
ROARING SPRING, PA ELLENWOOD, GA REMINGTON, IN

Trust Alliance Capital, Inc.
Salt Lake City, UT

TRUCK AND TRAILER FINANCING
...for the rest of us

Bank said no? We say yes.

- New and established businesses welcome •
- All credit types considered •

800-763-2810 ext 100
www.trustalliancecapital.com

ACCREDITED BUSINESS BBB Rating: A+

NATIONWIDE FUNDING

Pacifico Reflections - Details



by: Mike McGough

Her health had been failing and her prospects for survival did not look good. Doctors from around the country all offered the same grim prognosis. Even though her husband had become a captain of American industry, he stood beside her all but helpless. There was nothing his money or influence could affect.

Just as the family was about to resign themselves to a sealed fate, word reached them of a new surgical procedure. The family received the news as a ray of hope. Because of his wealth and influence he was able to have the two doctors summoned to the hospital where his wife was a patient. His sons and daughters were relieved that potential life-

saving help was on the way. But he, a pragmatic and no-nonsense man, knew that he faced a serious challenge. How would he choose the surgeon who would afford his wife the best potential outcome? Because the surgeon selected would have to commit to staying with his wife for at least the first week, having both of them engaged with one

patient was not an option.

The backgrounds of the surgeons provided no basis upon which to make a decision. Both surgeons had educational backgrounds and levels of experience that were remarkable. Their credentials were impressive and impeccable. References were so similar, that they appeared to be offered for the same person. Their patient survival rates were similar. Endorsements by patients, hospitals, and licensing boards for each of the surgeons provided no indications of superiority. Regarding the complicated and experimental surgical procedure in question, both doctors had performed the procedure the same number of times with similar results. Patients upon whom the procedure was performed stood about a fifty-fifty chance, even with the surgical advancements that came in the aftermath of World War II. The search for some indication upon which to make this decision seemed hopeless.

The family was provided all of the information available on both surgeons. The four adult children debated, but they arrived at no conclusion. As the family anxiously awaited the arrival of the surgeons, they stood by the bedside of the one who they loved and feared they would soon lose. Through the open door of the hospital room they watched the surgeons approach. Amazingly, but not surprisingly, the two men even looked alike. They were about the same height, the same build, and the same age. Was there noting that would separate these two very skilled physicians?

But then in an instant, as a result of a most simple and routine act, the industrial giant who wanted nothing more than to have his wife's life spared, found the indicator he was looking so desperately to find. As he and his children had entered the room, he dropped a small piece of tissue on the floor just outside of his wife's room. He

purposefully dropped it off to the side. As the surgeons were about to enter the room, one of them stooped to pick up the small piece of tissue laying on the floor. Interestingly, he was the surgeon who was the farthest away from the tissue.

Without hesitation the patient's husband stepped forward, greeted the surgeon who had not yet had time to dispose of the tissue, and said, "You will operate on my wife." He quickly thanked the other surgeon for his time, and told him that he would be compensated for his time and that all of his expenses would be covered. Relieved that a decision had been made, the other members of the family did not question the selection. They were happy that it had been made and that the surgery could take place. In short order arrangements were made, and the procedure was successfully performed. The surgeon did remain to the end of the first week, at which time he offered a welcome prognosis for a full recovery.

Sometime later one of his son's asked the industrial giant how he had made the decision. "It was simple," he answered. "When the surgeons were about to enter the room, one of them bent down to pick up a small piece of tissue I had purposefully dropped on the floor. Immediately, I knew into whose hands I wanted to place your mother's life."

"One of those men," he continued, "had enough pride in what he did and where he did it to care about an insignificant detail. One of them was not above tending to something far below his level of expertise and experience. I have found those characteristics to be indispensable in business and industry, and I assumed they may be important in surgery as well!"

Regardless of what you do in life, do it with pride, and never grow too big to take care of the details!!!

NEW PRODUCT + NEW PRODUCT + NEW PRODUCT + NEW PRODUCT + NEW PRODUCT



ELIMINATE DPF REGEN PROBLEMS



Untreated DPF	Treated DPF
	

**KEEP YOUR TRUCK OUT OF THE SERVICE BAY
START SAVING MONEY TODAY!**

www.betterdiesel.com

612-209-3079 | jgates@betterdiesel.com



PKY TRUCK BEAUTY CHAMPIONSHIP

LEARN MORE AT WWW.TRUCKINGSHOW.COM /PKY

THE PURSUIT OF EXCELLENCE

MARCH 28 - 30, 2019
AT THE 48TH ANNUAL MID-AMERICA TRUCKING SHOW
KENTUCKY EXPO CENTER, LOUISVILLE, KY

★ ENTER YOUR TRUCK AT WWW.TRUCKINGSHOW.COM ★



ATTENTION TRUCKERS AND TRUCKING ENTHUSIASTS...

GEAR JAMMER MAGAZINE

Presents two great calendars for 2019!



\$12 PLUS \$4 S&H FOR ONE
\$20 PLUS \$6 S&H FOR BOTH

FOR INFO CALL 508-212-9998
or e-mail mttconrad7@aol.com

Name _____
Address _____
Town _____ State _____ Zip _____
Phone _____

MAKE CHECK PAYABLE TO: Robert Conrad, 15 Concetta Dr, Mansfield, MA 02048

CLASS A FLATBED DRIVERS WANTED!

888-420-0529 x7091



TLX AWL TRANSPORT, INC.

A DIVISION OF AWL TRANSPORT

- Guaranteed Pay Starting Day-one
- Home Weekends
- No Hold Back on Pay
- Sign-on Bonus

CALL DAVID DERR AT 888-420-0529 x7091
Or apply online at www.tlxtransport.com

MOVIN'OUT.COM
OVER 900 TRUCKING JOBS!
Of all types

• MORE SHOW TRUCKS • MORE ARTICLES
• BACK EDITIONS

OVER 800 TRUCKS AND TRAILERS FOR SALE

Formatted to support all devices.



You've worked hard for what you've got and we work hard to **SAVE** you more!

- We **FOCUS** on helping you to build credit!
- Our fuel cards have **NO** monthly minimum usage fees.
- Our members are saving up to **35%** off the retail prices on Michelin tires!



MATS 2019
MARCH 28-30
TRUCKINGSHOW.COM

VISIT US IN BOOTH
76176

☎ 352-241-6000

🌐 www.truckerssolution.com

Kinedyne Introduces Ergonomically Advanced EASE-Z Winch Bars

BRANCBURG, NJ... Kinedyne LLC, a world-leading designer, manufacturer and distributor of cargo control technologies, including cargo securement, capacity and access solutions for the transportation industry, announced the formal introduction of its new EASE-Z Winch Bar family today. The EASE-Z Winch Bar is a patented Z-shaped winch bar that rotates 360 degrees, providing users with greater leverage. The bar comes in one standard model and two combination versions that have modified handles that can be used to release tension on chain binders. Traditional winch bars are straight with a slightly angled tip. While effective in many cases, the bars essentially function as a classic lever and make it more difficult for users to exert the proper amount of force when in certain positions or when clearance is limited.

The EASE-Z Winch Bar is different. The tough, heat-treated carbon-steel and mushroom-shaped head of the EASE-Z Winch Bar is tapered for easy insertion, and helps keep the bar seated in the winch cap, and preventing it from slipping out during revolution and when the user is applying torque. A knurled non-slip handle with a flanged grip ring on the bar's upper shaft helps prevent it from slipping out of users' hands even in moist conditions.

The Z-shaped EASE-Z Winch Bar can be rotated up to 360 degrees, enabling users to optimally position themselves and the bar to deliver superior leverage when tensioning winch straps. The rotation of the bar without having

to remove it from the winch cap eyelet provides a pivoting action that lets users quickly orient the bar as needed to avoid obstacles and to achieve optimum posture while applying up or down force.

"The EASE-Z Winch Bar is the ergonomically sensible alternative to traditional straight winch bars, and can be part of a fleet's plan to reduce work-related injuries," said Bob Dissinger director of sales – United States for Kinedyne LLC. "The contoured, extruded Z-shape, bent-bar offset design can reduce back, shoulder and arm strain by eliminating the need to exert excessive upward or downward force on the bar at awkward angles."

The bars are painted in high-visibility Kinedyne orange. The tool's angled shape is more stable and is unlikely to roll away when laid on the ground or on the deck of a flatbed trailer. The EASE-Z Winch Bar is available in three models. The 80177 standard bar comes in a length of 34 inches. The 80178 combination bar has a handle with greater girth, can be used to release tension on chain binders and comes in a length of 34 inches. The 80179 combination box-end model can also be used to release tension on chain binders and comes in a length of 39 inches.

Kinedyne's broad line of cargo control, capacity and access products can be purchased through Kinedyne's extensive distribution network, which includes thousands of outlets across North America. Users can find distributor locations near them by calling Kinedyne's customer service department at 800.848.6057 in the U.S.

Pilot Flying J Gives Back With Donation To Trucker Buddy International To Further Classroom Outreach

Birmingham, AL... Trucker Buddy International has announced an impactful gift from Pilot Flying J to support its mission to educate students around the nation on the value of the trucking industry. The donation was awarded as part of Pilot Flying J's \$2 million commitment to giving back in celebration of its 60th anniversary. Trucker Buddy International pairs over the road truck drivers with elementary school classrooms as pen pals. These pen pal relationships allow the driver, through communication directly with the elementary school teachers, to educate the students about the importance

of the trucking industry. The teacher is able to use various details about the driver's travels to teach math, history, reading, and writing. This gift from Pilot Flying J will allow Trucker Buddy to further its mission and pair more drivers with classrooms than ever.

Pilot Flying J's giving is focused on fueling those who serve by supporting military heroes and their families, and helping communities across the country improve the quality of life for people at home and on the road. To learn more about Pilot Flying J's 60th anniversary giving, visit www.pilotflyingj.com/giving-back.

THE ENTIRE TRUCKING INDUSTRY

1 million

SQ.FT OF EXHIBITS

1,000+

EXHIBITORS

70,000+

ATTENDEES

MARCH 28-30, 2019

at the KENTUCKY EXPO CENTER

The Mid-America Trucking Show is the largest annual heavy-duty trucking event in the world. With over 1,000,000 sq. ft. of exhibits and events, you will discover the newest industry products, experience hands-on demonstrations, talk with product experts and engineers, and participate in educational seminars and special events. MATS will improve your career and grow your business, so make plans now to join 70,000+ industry peers at MATS 2019.

For a full list of exhibitors, schedule of events, and to register to attend, please visit

www.TRUCKINGSHOW.com



The Best of the Best Announced by TCA and CarriersEdge

Alexandria, Virginia and Markham, Ontario... With a record number of nominees and finalists, the Truckload Carriers Association (TCA) and CarriersEdge are proud to announce the 2019 Best Fleets to Drive For.

"When it comes to working with drivers, our Top 20 Best Fleets to Drive For are North America's best-of-the best in the for-hire trucking segment," said CarriersEdge Chief Executive Officer Jane Jazrawy. "This recognition program is now in its 11th year, and each year we've seen fleets up their game—making a positive difference in the lives of drivers with innovative programs."

The 2019 Top 20 Best Fleets to Drive For are:

- * American Central Transport, Inc. - Kansas City, Missouri
- * Bennett Motor Express - McDonough, Georgia
- * Bison Transport - Winnipeg, Manitoba
- * Boyle Transportation - Bil-

lerica, Massachusetts
 * Central Oregon Truck Company, Inc. - Redmond, Oregon

* Crete Carrier Corp - Lincoln, Nebraska

* Epes Transport System, LLC - Greensboro, North Carolina

* Erb Transport - New Hamburg, Ontario

* FTC Transportation, Inc. - Oklahoma City, Oklahoma

* Garner Trucking, Inc. - Findlay, Ohio

* Grand Island Express - Grand Island, Nebraska

* Halvor Lines, Inc. - Superior, Wisconsin

* Landstar System, Inc. - Jacksonville, Florida

* Maverick Transportation, LLC - North Little Rock, Arkansas

* Motor Carrier Service LLC - Northwood, Ohio

* Nussbaum Transportation Services, Inc. - Hudson, Illinois

* Prime Inc. - Springfield, Missouri

* Thomas E. Keller Trucking

Inc. - Defiance, Ohio

* TLD Logistics Services, Inc. - Knoxville, Tennessee

* Transpro Freight Systems Limited - Milton, Ontario

In addition to the Top 20, TCA and CarriersEdge identified five Fleets to Watch (honorable mentions).

The Top 5 Fleets to Watch:

* Fortigo Freight Services Inc. - Etobicoke, Ontario

* Leavitt's Freight Service - Springfield, Oregon

* Liberty Linehaul Inc. - Ayr, Ontario

* Roehl Transport, Inc. - Marshfield, Wisconsin

* TransLand - Strafford, Missouri

Three fleets have also achieved the milestone of five consecutive years on the list: Boyle Transportation, Nussbaum Services and TLD Logistics.

To be considered for the Best Fleets program, companies operating 10 or more trucks had to receive a nomination from at least one of their company

drivers or owner operators. The fleets were then evaluated using a scoring matrix covering a variety of categories, including total compensation, health benefits, performance management, professional development, and career path/ advancement opportunities, among other criteria. Driver surveys were also conducted to collect input from drivers and independent contractors working with the fleets.

According to John Lyboldt, TCA's president, the Best Fleets program and its annual list of the Top 20 has grown to become one of the most anticipated announcements in the industry. "The winners have set the bar high when it comes to keeping their professional truck drivers engaged while also providing a superior work environment. This coveted contest reveals the tremendous efforts put forth by these driver-centric companies."

"We do a very thorough analysis and take a deep dive

into each fleet's programs," mentioned Jazrawy. "An important component in the scoring process is analyzing driver feedback on the company and then comparing it with management's comments. The two need to align in order for fleets to score well. This year's Top 20 had an average driver satisfaction rate over 91%, and annual driver turnover under 35%, so what they're doing is obviously working."

An overall winner -- in the large and small fleet categories -- will be named during TCA's Annual Convention, being held March 10-13 at the Wynn Las Vegas Resort. EpicVue and DMC Insurance sponsor the overall winner awards.

For additional information on the Best Fleets to Drive For program, follow the hashtag: #BestFleets19 on TCA's Twitter and Facebook pages; or, go to <http://www.bestfleet->

Turnover Rate at Large Truckload Carriers Falls in Third Quarter - Drop Erases Yearlong Increase in Churn Rate

Arlington, VA... American Trucking Associations Chief Economist Bob Costello said the turnover rate at large truckload carriers fell 11 percentage points in the third quarter, undoing two quarters worth of increases in the annualized churn rate.

The turnover rate fell 11 percentage points—dropping it to 87%, marking its lowest point since the first quarter of 2017 when it stood at 74%. The drop also reverses two consecutive quarters of increases in the turnover rate, which had driven up the churn rate as high as 98% – 10 points higher than at the end of 2017.

"The drop in turnover can be potentially explained in a few ways," Costello said. "First, large pay increases fleets have been offering appear to be working, and drivers are remaining with their current carrier. Second, we did see a softening of freight markets in the third quarter from the incredibly strong pace it had set earlier in the year. Historically, softer freight volumes lead to lower driver turnover."

Also in the third quarter, the turnover rate at small carriers—fleets with less than \$30 million in annual revenue – remained unchanged at 72%, and the churn rate at less-than-truckload carriers fell four percentage points to 10%.

Are you using antibiotics, steroids or anti-fungals to treat a respiratory infection? Still sick and feeling worse?

We use a natural, *laboratory and clinically proven* antimicrobial that kills bacteria, fungus and virus without harming the patient.

We use **RESPIRATORY RELIEF** from **NATURE'S RITE™**

25% OFF w/ Coupon
Code MOR25
 For use in a nebulizer

100% MONEY BACK GUARANTEE

Order online at MyNaturesRite.com or call 800-991-7088

We get calls & orders from people who have tried all sorts of prescription medications that do NOT get rid of their respiratory infections. Time after time the infections clear up in a few days with Respiratory Relief. We shake our heads and wonder, "Why don't they try this first?" Now you can.

TRUCK BOSS SHOW

ALL THINGS TRUCKING
 News • Gear • Reviews • Demos
 Rig Report • How-to's • Trade Shows

@truckbosshow

MOVIN' OUT Calendar of Events

Sponsored by



March 9 – 2nd Annual Shine In the Pines – 575 Southern Pines Rd., Dublin, GA. Truck and Chrome Show, Chicken Light Show at dark. Convoy on Saturday morning. Food, Fun, Vendors, Entertainment, Music. See us on Facebook for more info!

March 28-30 – Mid-America Truck Show – Kentucky Fair and Expo Center, Louisville, KY. For More info visit www.truckingshow.com

April 26-28 – 20th Annual 75 Chrome Shop Truck Show – 75 Chrome Shop, located off Exit 329 I-75; 419 E State Road 44 Wildwood, FL 34785. For more info, call 866-255-6206 or visit them on the web at www.75chromeshop.com

May 12 – 30th Anniversary Mother's Day Truck Convoy – Burle Industries, 1000 New Holland Ave. (Rt. 23), Lancaster, PA. Raising awareness and funds for Make-A-Wish® Philadelphia, Northern Delaware & Susquehanna Valley. Fun filled day for the entire family. 500+ trucks, food, games, live bands. For more info call 717-283-4880

May 18 – 19th Annual Greater Cincinnati Chapter of the ATHS Truck Show – Howard Trucking, 10955 Haddix Rd., Fairborn, OH. 45324. All Trucks Welcome! Truck Show, Slow Truck Drag Race, Door Prizes, DJ, Food Concessions. More info, call 937-878-3370 or email: howardtrk@yahoo.com

May 31- June 2 – ATHS Convention – Grand Sierra Resort, Reno, Nevada. For more info, visit www.ATHS.org or phone 816-891-9900.

May 30 – June 2 – 16th Annual Wheel Jam – South Dakota State Fairgrounds, 431 18th St. SW, Huron, SD. For more info visit www.wheeljamtruckshow.com

June 8 – The Jane Harting Cancer Benefit Truck Show Picnic – Elite Service, Inc, 905 Stone Hill Rd., Denver, PA. Classic cars/small trucks also welcome. For more info contact Ron or Rebecca Yoder at 717-419-5737.

June 15-16 – 8th Annual Ohio Vintage Truck Jamboree – Ashland County Fairgrounds, 2042 Claremont Ave., Ashland, OH. 44805. Truck Light Display, Trucking Memorabilia Display, Truck Model Contest, Door Prizes, Swap Meet, "Country Convoy" Dinner Cruise, Raffles, Jake Brake Competition. For more info visit www.ohvinttrkjam.com or call 330-682-1707 or email: wep515@gmail.com

June 22 – Transport For Christ Truck Rally – Lebanon Expo, Lebanon, PA. For more info visit www.transportforchrist.org or phone 717-665-6347.

July 11-13 – 40th Annual Walcott Truckers Jamboree – Iowa 80 Truckstop, I-80 Exit 284, Walcott, IA. Super Beauty Truck Show, Antique Truck Display, Trucker Olympics Games, Exhibits, Fireworks, Live Music and much more!! For more information go to <http://iowa80truckstop.com/trucker-jamboree/>

August 2-4 – Carlisle Truck Nationals – Carlisle, PA Big Rig Show and Shine. Monster Truck Shows, Vendor Midway and Truck Themed Swap Meet, Kids at Carlisle Activity Center. For more info call 717-243-7855 or visit www.carlisleevents.com

July 20 – 2nd Annual Gear Jammer Magazine Truck Show – Auction Acres, 35 Main St., Brimfield, MA 01010. All proceeds benefit the Doug Flutie, Jr. Foundation for Autism Awareness. For more info call 508-212-9998.

July 26-27 – ATCA Keystone Chapter Truck Show – East Freedom, PA across street from East Freedom Fire Hall. For more info visit www.keystonetruck.org or call 814-224-2084.

July 26-28 – TopGun LargeCar Shootout Truck Show - Rantoul National Aviation Center, Rantoul, IL For more info email: topgunshootout@yahoo.com or phone 217-202-1474.

August 3 – 15th Annual ATHS Iowa-Nebraska Classic Truck Show – Sapp Bros. Truck Stop, Northwest Parking Lot, I-80 exit 440, Omaha, NE. Free Truck Show! Free cash plaques and lunch for show entries. Food, vendors, music, transportation memorabilia and fun! For more info call Jim Ernst at 402-895-8040 or Russel Spawn, Jr. at 402-680-6121.

August 9-10 – Wapun Truck-N-Show – 30th Anniversary – Waupun, WI. For more info call 920-324-9985 or visit www.wapuntrucknshow.com or find us on Facebook.

August 16-17 – Eau Claire Big Rig Truck Show 10th Anniversary Celebration – Northern WI State Fairgrounds, Chippewa Falls, WI 54729. For more email info@etruckshow.com. Or phone (715) 832-6666

August 22-24 – The Great American Trucking Show – Kay Bailey Hutchison Convention Center, 650 S. Griffin St., Dallas, TX. For more info visit www.truckshow.com

October 28-31 - North American Commercial Vehicle Show (NACVS) – Georgia World Congress Center, Atlanta, GA. For more info visit <http://nacvsshow.com>

If you would like to list an upcoming show or event, send all the details including a telephone contact number to:

Movin' Out, P.O. Box 97, Slippery Rock, PA 16057 or fax us at 724-794-1314,

email: movinout@zoominternet.net.

Visit us on the web at www.movinout.com



GET YOUR FREE CATALOG!

- Go online to www.iowa80.com and request your FREE CATALOG of the finest selection in Chrome and Professional Trucking Accessories!
- Or Call Toll Free – 866-4-IOWA80 (866-446-9280)
- Shop online today! www.iowa80.com

IOWA 80.COM



Truck Accessories For The Professional Driver

MO 2019

LargeCar Mag

FAMILY GATHERING - 2ND ANNUAL "UNITED WE ROLL" TRUCK SHOW

Saturday, May 25th, 2019 - 8 AM

Proceeds donated to Relay for Life American Cancer Society

In honor of Sal Castiglione
Non-judged, no trophy event
\$20 per truck

Chinese auction, vendors, DJ, kids zone/games, food, trucks, antique cars and more

For more info:
www.largecarmag.com
717 806 8907
or email Michele@largecarmag.com

Classic Auto Mall
6180 Morgantown Road
Morgantown, Pennsylvania 19543

LARGEARMAG.COM

FLAT TIRE? OUT OF GAS? STRANDED?

DIAL *11

for emergency assistance

ANYWHERE

on the PA Turnpike.



Working Show Truck Of The Month

Kaleb Hammett
Hammett Excavation

Sponsored by
Shell
ROTELLA
The Engine Oil That Works As Hard As You.



By Robert Conrad

Kaleb Hammett may only be 21, but he grew up around equipment & trucks and fell in love with them as a young boy. His grandfather Harry Hammett started Hammett Excavation in 1963, and his dad, Gaylon presently runs the office and the excavation side of the business.

Kaleb trucks with one of the hottest heavy haulers around, this 2013 Peterbilt 389, and he usually pulls the 2015 Trail King 55-ton lowboy seen in our photos. The truck was built by family friend Jake Lindamood and it's a rolling tribute to Kaleb's grandfather who passed

away in 2014 after battling lung cancer.

This truck is a stunning combination of beauty & beast with a full double frame, dual steering boxes, a 20k front axle, and 53k rears. It features an 18-speed transmission, a C-15 6NZ CAT engine, and a 2-speed rear end with 3:90's for the high and 5:36's for the low. Custom features include a Valley Chrome bumper with a 12 Gauge Customs flip kit a custom rear light bar & front T-bar, and custom Peterbilt steps to the deck plate. Roll On Customs made solid billet aluminum lug nut covers with Kaleb's grandfather's signature and the company name engraved in them! Inside the cab there's a painted floor with logos, custom upholstery, and a number of polished trim pieces.

When he's not trucking, Kaleb enjoys attending truck

shows and he credits Evan from Evan's Polishing for helping keep the truck show ready! Kaleb has won a number of awards, including a 1st Place at the 2018 Shell Super Rigs, Best of Show in Dallas at GATS, and Best of Show at the GBATS show at 4 States Trucks. Kaleb Hammett and Hammett Excavation's hot heavy hauler are certainly a winning combination and should be for years to come!



Skelton Truck Lines

NOW HIRING

Team Owner Operators
& Team Company Drivers

HIGHEST PAY IN THE INDUSTRY
WITH A RETENTION RATE OF 95%

We Require

- 3 Years Driving Experience
- Good MVR
- Ability to cross Canada /US border
- Hazmat Endorsment
- Enhanced CDL is an asset

We Offer

- Fuel surcharge and Safety Bonus
- Paid Pick Ups/ Deliveries
- Paid Statutory Holidays
- Partial Medical
- Company Paid Insurance
- Paid US/Canada Border Crossing
- Paid Layover/Waiting Times
- 401K Contributions
- Per Diem Pay Schedule
- Paid Orientation

Owner Operator Team
Average \$1.75/Hub Mile

Company Teams
Average \$0.86/Hub Mile

Call or email Leisa Shyshko at
800-387-9796 ext. 231

lesia.shyshko@skeltontruck.com





THEY MAY NOT SEE YOUR HARD WORK **BUT WE DO**

Your job demands something most people can't see — hard work and dedication. We see the relentless efforts you put in day in and day out. It doesn't go unnoticed. That's why we work just as hard to make sure our most advanced technology is in every bottle of Shell Rotella® engine oil. Because we know just as well as you, that sometimes hard work is its own reward. Learn more at insiderotella.shell.com



**Shell
ROTELLA**

The Engine Oil That Works As Hard As You.

Available at:

