

# MOVIN' OUT

Our 41<sup>st</sup> year

P.O. Box 97  
Slippery Rock  
PA 16057  
PRESORTED STANDARD  
U.S. POSTAGE  
PAID  
WILLIAMSPORT, PA  
PERMIT NO. 4  
CHANGE SERVICE REQUESTED

Vol. 41 No. 4  
April 2016

www.movinout.com

FREE COPY

"THE JOURNAL OF THE TRUCKING INDUSTRY"

## 26th Annual Waupun Truck 'N Show



High Gear Photography

The 2016 Waupun Truck 'N Show was host to many spectacular Big Rigs! Turn to Page 17 for more photos. - Photo by High Gear Photography -

### Truckers Solution – Real Solutions For Real Truckers



Left to right: Vickie Roberts, Adriene Rainey, Kelly Rainey, Ashley Oliver

**By Steve Pollock**  
ORLANDO, FL... "With Truckers Solution® we're part of a program that is not a rebate program, our savings are instant on every purchase, whether it be fuel...or any of the other Truckers Solutions® products and services, we save up front, GREAT Job, keep it up..." says Brenda, Pam & Marty Waddell of Waddell Transfer, Atkins, VA.

Truckers Solution began in February 2011 as the brainchild of Phillip Fulmer, Owner of Carroll Fulmer Trucking of Groveland, Florida. Phillip was looking for a way for small fleets and owner-operators to get discounts like the large fleets on the products they need to operate their trucks. Truckers Solution started with fuel and then grew to other products and services required by commercial vehicles and their owners.

Truckers Solution works in this manner:  
You must become a member – but the membership is FREE. Truckers Solution has negotiated volume discounts with vendors. The discounts are based upon volume, so the more members purchase, the greater the discounts become. The discounts are applied immediately at the time of purchase. Truckers Solution receives a commission from the transaction with the vendor. Membership is available to individuals and fleets and the larger the volume of purchases, the larger the discounts for the members.

continued on page 26

### Miller Truck Lines – Providing World Class Transportation Services



James, Jim (Jimmy), Don (Tiger) and Bobby Miller

**By Steve Pollock**  
STROUD, OK... Miller Truck Lines was founded in 1983 by James and Bonnie Miller, who purchased three used Freightliners to haul for the Kroger Foods grocery store chain. Today the company has grown to over 400 trucks and is still family owned and operated by the Millers and their 3 sons, Jim, Don and Bobby.

Miller Truck Lines' success and growth can be attributed to two key components: treating their drivers and employees well and diversifying their operations. James, Jim, Don and Bobby all have current CDLs and have driven over-the-road for the company at some point in their careers. This has given the Millers a deep respect and understanding of what Professional Truck Drivers must deal with on a daily basis. The respect the Millers have for their drivers allows the company to enjoy a driver turnover rate that is well below industry averages. Professional Truck Drivers like working for Miller Truck Lines. Although grocery hauling provides steady work, even when the economy slows, the Millers realized that by diversifying their services they could develop a broader customer base, providing additional freight for their drivers, especially when times get tough.

The company has evolved to operate dry vans, reefers, flatbeds, tankers, pneumatics and even some roll-offs. The fleet is continued on page 18

## Detroit Unveils New DD5 Engine

# DRIVERS YOU CAN NOW

# APPLY FOR YOUR DREAM JOB AT

## MOVIN'OUT.COM

### Safe and Secure with No App Spamming!

ALSO

- Search Leading Dealer Inventories for Trucks and Trailers
- See Hundreds of Show Trucks in the Photo Galleries as well as the Entire Publication

ALL FOR FREE AT

## MOVIN'OUT.COM

Bringing Great Drivers and Great Carriers Together



INDIANAPOLIS, IN... Daimler Truck North America (DTNA) gave the public its first glimpse of its new Detroit DD5™ at the NTEA Work Truck Show in Indianapolis. The Detroit DD5 is the first of two new medium duty engines, with the Detroit DD8™ planned to follow in 2018.

The proprietary engine platform was first announced in October 2014, and in November 2015 it was announced that DTNA would invest \$375 million to bring medium duty engine production to its Redford, Michigan facility. Initial production of the medium duty line will take place in Manheim, Germany before shifting to United States in 2018. The DD5 will be available for

orders later this year in Freightliner Class 5/6 M2106 trucks ideally equipped for pick-up and delivery applications. More extensive availability throughout DTNA's product portfolio will begin when production shifts to the Redford facility in 2018.

The DD5 will initially offer two power ratings, a 210HP/575ft-lb torque and a 230HP/660ft-lb torque, with the plans for additional ratings once the production shifts to the Redford facility in 2018. In addition, Detroit also announced the engines will have a 45,000 mile maintenance interval and the engines will be equipped with the award winning Detroit™ Connect Virtual Technician™ remote diag-

nostics service. The DD5, along with all other Detroit engines, will meet the GHG17 standards early.

Detroit offers a line of heavy-duty diesel engines, axles, transmissions, safety systems and telematics products for the commercial transportation industry in both the on-highway and vocational markets. Detroit™ products are sold and serviced through a network of hundreds of locations throughout North America. Detroit™ is a brand of Detroit Diesel Corporation, a subsidiary of Daimler Trucks North America LLC.

For more information, or to locate the nearest Detroit location, visit [www.DemandDetroit.com](http://www.DemandDetroit.com).

# Panelite®

by  DIETER'S



## ORIGINAL EQUIPMENT SUPPLIER

About Dieter's:

- Largest manufacturer of stainless steel accessories in North America.
- Main supplier of production line & aftermarket stainless steel products to all North American truck manufacturers.
- Highest quality standards in the industry.
- TS16949, ISO9001, ISO14001 certified.
- Only top quality 304 non-magnetic stainless steel used.
- Manufacturing quality products in North America since 1976.
- Products available for purchase at all OEM dealerships & select Chrome Shops in North America.

[www.panelite.com](http://www.panelite.com)  
[www.dietersaccessories.com](http://www.dietersaccessories.com)



1-800-331-7952



[info@panelite.com](mailto:info@panelite.com)  
[inquiries@dietersaccessories.com](mailto:inquiries@dietersaccessories.com)

# Firestone

# \$429.99 PER TIRE\*

WHEN YOU BUY 2 OR MORE  
**STEER, DRIVE OR TRAILER**  
LOW PRO 22.5 14-PLY TIRES

\*Price does not include F.E.T., Mounting Labor, Balancing, Valve Stems, State or Local Taxes.

## FREE

### Alignment Check

When You Buy  
Any 2 Steer Tires

## FREE

### 3-Axle Alignment

When You Buy  
Any 8 Drive Tires

# ✓ Guaranteed Lowest Price\*\*



## TRUCK SERVICE

## PETRO:LUBE®

Offer valid March 1 – April 30, 2016 at participating locations. \*\*Guaranteed lowest price available on purchase of new tire sets. Present copy of the competitors ad or written tire price quote to the service writer at the time of purchase and we will match it. Guarantee does not apply to verbal quotes, Must be the same tire product code (brand and size).

Visit [ta-petro.com](http://ta-petro.com) or find us on



# Off The Beaten Path

by Pam Pollock

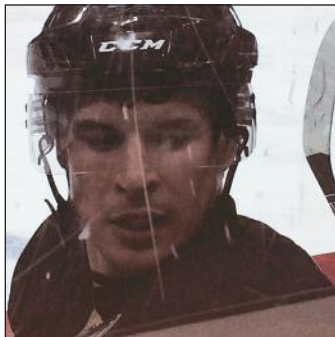

that you lousy no-good rotten \*%\$#@!" I suspect that if I were a hockey player, I would be in the penalty box for the majority of the game.

You may want to keep all of this in mind and think twice about ticking me off or you may just end up being

crosschecked by moi. I'm easily recognizable; I'm the little short granny in a Pens jersey who will be struggling to stay upright on her skates. Oh - and I will be wielding a big stick and yelling. All's fair in love, war --- and hockey.



## Ice Ice Baby...

One look at me and you will immediately notice my stature - or lack thereof. I'm short; most of my family members are short. We've been ridiculed and mocked and teased relentlessly over the years. But while I personally don't measure up on the growth chart, I more than make up for it with my very vocal personality and fiery Irish temper. I will unload on anyone who has pushed my buttons or is picking on someone who can't or won't fight back.

I watch a lot of football, baseball and hockey and of course I root for my home teams - The Pittsburgh Steelers, Pirates and Pens. My true sports passion is hockey. I don't attend a lot of games because my snobbish attitude of wanting seats down near the ice conflicts with the contents of my pocketbook. I usually go to at least 1 game a season and I watch the others on TV.

I feel a kinship with my hockey players. I empathize with them - how dare that player from the other team strip the puck from him! That's when I leap from the couch and yell, "Slam him! Slaaaaaaam him! Rap him with your stick!"

I get excited when there's a fight! I fist pump my arm and scream, "Fight! Fight! Fight!" The more players that leap into the fray and pile onto jerk from the other team, the merrier I get.

I have discovered that if I have had a bad day at work and there's a hockey game on that night, I can release so much of my pent-up frustration and anger. As my Pens players shove an opponent up against the wall, I imagine that it is me out there on the ice in full uniform and I mentally yell, "Take

## The Hunter Family of Companies Acquires New Location

Butler, PA... The Hunter Family of Companies is pleased to announce the purchase of Pocono Peterbilt, a full line medium and heavy-duty Peterbilt truck dealership, located in Northeast Pennsylvania.

Located at Exit 302 off of Interstate 80, Hunter Pocono Peterbilt offers new and used truck sales, parts sales, body shop, and service.

"We are excited to expand the Hunter network into Northeast Pennsylvania and be able to better serve our customers traveling in that area," said President Jeffrey Hunter.

For more information about our newest location, Hunter Pocono Peterbilt, call 800-776-2738.

A leader in Heavy Commercial Trucks since 1938, Hunter provides an unparalleled customer experience with a wide array of offerings. Hunter has enjoyed long-standing relationships with premium-quality manufacturers; Peterbilt Motors Company and International Truck and Engine. We provide 21 service points across Pennsylvania, New York, New Jersey, West Virginia, and Ohio.

## DIESEL INJECTION AND PARTS OF I-80 INC.

I-80, Exit 29 Barkeyville, PA

COMPLETE PARTS & SERVICE FOR ALL DIESEL ENGINES

**\$75 per Hour Labor Rate**

We can NOW upgrade your existing computer. Same day in-house service

- High output turbos
- High performance mufflers
- Custom built radiators
- Crankshaft dampers
- Performance exhaust manifolds
- Stainless Steel water tubes

### Lucas Fuel Treatment

\$85 Per Case



Lucas Oil Stabilizer  
\$90 Per Case



ALL LUCAS LUBRICANTS IN STOCK



Off I-80 Exit 29 • Truck Parking



(814) 786-7916

Open Monday - Friday 8:00 am to 5:00 pm

Owners  
Ron Mahen  
Bruce Mallinson

## BROKERED LOADS

Loads from Youngstown area to all points

★ TERMINAL PAY ★ PERMANENT LEASE ★



"The Wright Place"

(330) 534-5677

Located on Truckworld Boulevard • I-80 Exit 234 • Hubbard, Ohio

**MAURY DONNELLY & PARR, INC.**  
Baltimore MD.  
INSURANCE SINCE 1875

## WRITING TRUCK INSURANCE IN 48 STATES

- Bobtail-Physical Damage
- Liability
- Health and Disability Plans
- Specializing in Small Fleet and Owner/Operators

Call Gary C. Wirth

(800) 638-9202 x214

email: gwirth@mdpins.com



"THE JOURNAL OF THE TRUCKING INDUSTRY"

118 1/2 FRANKLIN STREET - P.O. BOX 97

SLIPPERY ROCK, PA 16057

PHONE: 724-794-6831 • FAX 724-794-1314

ISSN 1524-2684 www.movinout.com

E-Mail: movinout@zoominternet.net

All Rights Reserved

PUBLISHER  
Steven M. Pollock

EDITOR  
Pam Pollock

NATIONAL SALES  
Autumn Kellogg  
George Miller  
(717) 767-1523

FEATURES WRITERS  
Heather Hogeland  
Roger Hogeland  
Robert Conrad  
Laura Hubka  
Ken Hubka  
Chad Violet

CONTRIBUTING WRITERS  
Rev. Robert E. Harris  
Dr. Michael McGough  
Bruce Mallinson  
Linda Caffee

FOUNDED IN 1975 BY  
Strickler W. Pollock



### Advertising/Editorial Policy

Movin' Out welcomes the submission of articles, news releases, editorials & letters for publication. Articles should be no longer than 2 double-spaced pages, typed. No article - including those requesting anonymity will be published without author's name, address and phone number. Movin' Out reserves the right to refuse publication. Opinions expressed in letters and editorials are those of the author and not necessarily those of Movin' Out. The publisher assumes no responsibility or liability for typographical errors, and reserves the right to regulate ad placement and/or reject any ad or editorial.

**RADIATORS REPAIRED or RECORED**  
Auto • Truck  
Industrial

ALL WORK GUARANTEED

**Joe's Radiator Service**

Next to Truckworld I-80 & S.R. 62 & 7 Hubbard, Ohio  
(330) 534-7829

## SUBSCRIPTION ORDER

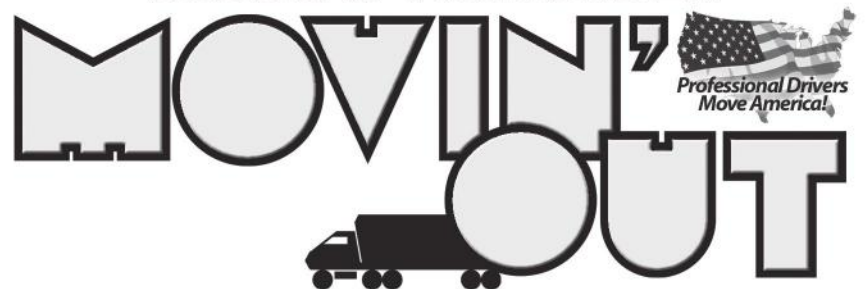

A Full Year 12 Great Issues \$20.00

(CANADA AND OTHER FOREIGN COUNTRIES \$22.00)

(Please allow 4 to 6 weeks for arrival of your first issue, no changes or new subscriptions will be accepted over the phone)

Name \_\_\_\_\_ E: Mail \_\_\_\_\_

Address \_\_\_\_\_

City \_\_\_\_\_ State \_\_\_\_\_ Zip \_\_\_\_\_

Enclosed check or money order with subscription blank and mail to:  
**MOVIN' OUT P.O. BOX 97 SLIPPERY ROCK, PA 16057**



# HUNTER

TRUCKS • PARTS • SERVICE

SINCE 1938

## INTRODUCING OUR NEWEST LOCATION!

### Hunter Pocono Peterbilt

I-80 Exit 302 in Bartonsville, PA

1328 Golden Slipper Road Bartonsville, PA 18321

**Leasing & Rental**  
**Body Shop for all makes**

**Financing**  
**Truck Sales**

**Parts & Service**  
**Trailer Sales**

## THE HUNTER FAMILY OF COMPANIES

### Locations to Serve You in PA, OH, NJ, NY, and WV

   
**Hunter Keystone Peterbilt**  
**Allentown, PA**  
9981 Old Rt. 22  
I-78 Exit 13 Breinigsville, PA  
**800.874.3020**

  
**Hunter Pocono Peterbilt**  
**Bartonsville, PA**  
1328 Golden Slipper Road  
I-80 Exit 302 Bartonsville, PA  
**800.776.2738**

   
**Hunter Truck Sales & Service Inc.**  
**Brookfield, OH**  
3500 Parkway Drive (Rt. 82)  
Brookfield, Ohio  
**330.448.6295**

   
**Hunter Truck Sales & Service Inc.**  
**Butler, PA**  
519 Pittsburgh Rd.  
(RT.8) Butler, PA  
**800.999.7744**

   
**Hunter Truck Center**  
**Butler, PA**  
174 Oneida Valley Road,  
Butler, PA 16001  
**724.282.1456**

  
**Hunter Leasing, LLC**  
**Butler, PA**  
174 Oneida Valley Road,  
Butler, PA 16001  
**724.282.0641**

   
**Hunter Buffalo Peterbilt**  
**Buffalo, NY**  
2370 Walden Ave.  
Buffalo, NY  
**800.400.9537**

   
**Hunter Jersey Peterbilt**  
**Clarksburg, NJ**  
524 Monmouth Rd.  
Clarksburg, NJ  
**866.589.4061**

   
**Hunter Keystone Peterbilt**  
**Clearfield, PA**  
160 Cresswood Dr.  
(I-80) Exit 120 Clearfield, PA  
**877.736.8940**

  
**Hunter Leasing, LLC**  
**Etna, PA**  
350 Poplar St.  
Pittsburgh, PA  
**866.781.2846**

   
**Hunter Truck Sales & Service Inc.**  
**Emlenton, PA**  
6390 Clintonville Rd.  
(I-80) Exit 42 Emlenton, PA  
**866.802.6340**

  
**Hunter Erie Truck Sales**  
**Erie, PA**  
8125 Wattsburg Rd.  
(I-90) Exit 29 Erie, PA  
**877.736.8930**

   
**Hunter Truck Sales & Service Inc.**  
**Eau Claire, PA**  
101 E. Main St  
(RT 58) Eau Claire, PA  
**800.842.8092**

  
**Hunter Keystone Peterbilt**  
**Lamar, PA**  
9 Clay Drive  
Mill Hall, PA  
**877.955.4004**

   
**Hunter Keystone Peterbilt**  
**Lancaster, PA**  
1463 Manheim Pike  
Lancaster, PA  
**800.243.2458**

   
**Hunter Jersey Peterbilt**  
**Pennsville, NJ**  
454 North Broadway  
Pennsville, NJ  
**877.222.2163**

  
**Hunter Leasing, LLC**  
**Philadelphia, PA**  
9801 Blue Grass Road  
Philadelphia, PA 19114  
**(215) 856-7601**

   
**Hunter Truck Sales & Service Inc.**  
**Pittsburgh, PA**  
4637 Campbells Run Rd.  
Pittsburgh, PA  
**800.438.3397**

  
**Hunter Truck Sales & Service Inc.**  
**Swedesboro, NJ**  
2320 High Hill Road  
Swedesboro, NJ  
**844.340.1782**

   
**Hunter Truck Sales & Service Inc.**  
**Uniontown, Pa**  
100 Hunter's Way  
Smithfield, PA  
**800.257.8782**

  
**John's Truck Parts**  
**Wyano, PA**  
141 Huntingdon Road  
Wyano, PA  
**844.288.7825**

  
**Hunter Truck Sales & Service Inc. Wheeling WV.**  
I-70 Exit 11  
1 W. Alexander Rd  
Valley Grove WV.  
**888.847.1038**

[www.HUNTERTRUCKSALES.com](http://www.HUNTERTRUCKSALES.com)



# High Performance Diesels

with Bruce Mallinson

Back in the 1980's Cummins Engine Company made a .013 thicker head gasket for engine blocks that were resurfaced. It was an ingenious idea, because as the block is resurfaced the compression ratio of the piston is increased because it's now closer to the top surface of the block. As compression ratio increases, the volumetric efficiency decreases and the horsepower decreases. Volumetric efficiency is the engine's ability to ingest air. A turbocharged engine with a lower compression piston will ingest

more air than a high compression piston. So when the block is resurfaced the compression ratio is raised. The .013-inch thicker head gasket for the Big Cam Cummins Engine was an ingenious idea and now with all of the diesel engines being overhead camshafts it's even more of a problem. As the decrease in deck height moves the camshaft and cam gear close to the idler gear it rotates the camshaft. This is a particular problem with the 12.7 liter 60 Series Detroit. Think about this, when the head is resurfaced it also

moves the camshaft closer to the idler gear. So with resurfacing the block and the head, this problem is compounded. This is a necessary evil; blocks and heads must be resurfaced in order to maintain a good seal of the head gasket. At Pittsburgh Power we discovered this problem with the 12.7 Detroit while building several engines for our clients. There was not enough material to resurface the block and maintain the proper piston to deck height. At this time, we were not thinking about the rotation of the

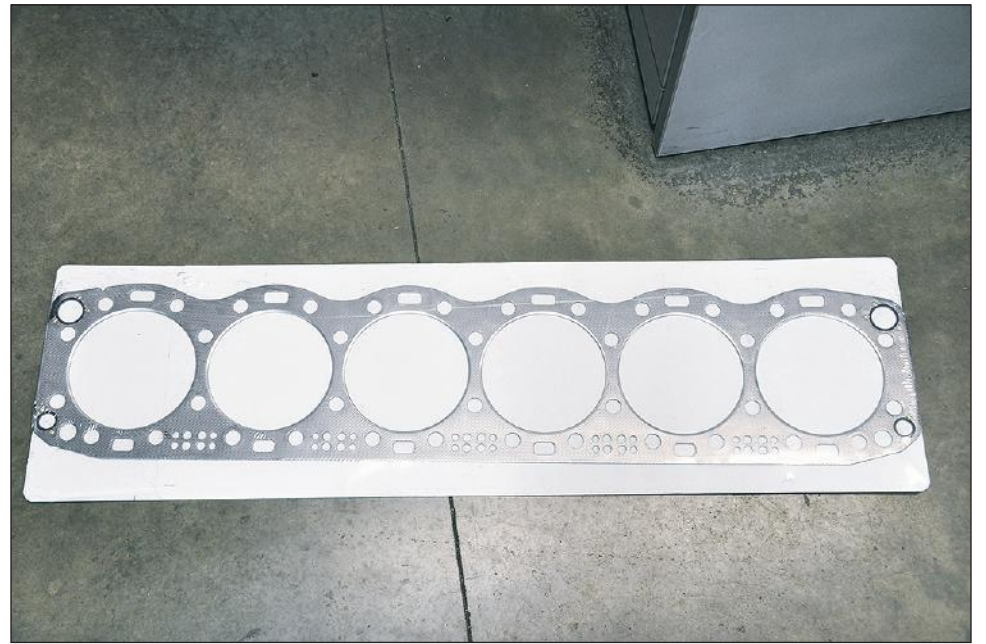

**PITTSBURGHPOWER.COM**

camshaft, we were more concerned with the compression ratio going too high and loosing performance. The valves can also hit the piston during a hard pull if the piston to deck height is too high. We are always looking for cures for the engines we work with and knowing the Cummins .013-inch gasket for the Big Cam solved this problem we wanted a head gasket for the 60 Series Detroit that would restore the piston to deck height. It's taken one year to design and have manufactured a .012-inch thicker head gasket for the 60 Series and the first one is now in service. On the dyno we gained 27 horsepower to the rear wheels without changing anything other than the head gasket, and the gear train on the front of the engine became a lot quieter. Other changes we noticed was the engine ran smoother, was quieter and smoked less even when the engine was cool. If you are in the process of having your 60 Series rebuilt, please have your mechanic check the piston to deck height with a dial indicator and if it's near the minimum spec you just might want to install a Pittsburgh Power .012-inch thicker head gasket.

expect to see these engines run in excess of 1 million miles with EGR, DPF and DEF running perfectly. For the past 39 years we have always looked for ways to improve the Cummins Engine and we feel that we have hit a HOME RUN for owner-operators with the 2008 and newer ISX Cummins keeping the engine completely legal. You can now have horsepower, torque and fuel mileage and run in and out of California and be completely legal and smoke free.

The Owner-Operator Snowmobile Conference is now over and all who attended had a wonderful time. We had a total of 27 people, 6 of them were women and we met at the Togwotee Mountain Lodge in Wyoming. The riding on Friday was good, Saturday it snowed most of the day and we still rode and Sunday, we had great riding. Saturday night we watched the movie "Convoy" and like last year as we watched "Smokey and the Bandit", the comments for owner-operators are always entertaining. It was neat to see the old trucks that many of us have driven and worked on. This was our eleventh year riding together and many of the owner-operators want to get

together twice next year. If you have never participated in a motorized sport with a group of owner-operators, you are missing out on a great time. We talk trucks, motorcycles, and snowmobiles and ride hard on the mountains. We really need to get together to do a motorcycle trip someday.

I want to say thank you to Michelle Buzalsky of Riverton, WY for being our tour guide and avalanche patrol. She is the president of the snowmobile club in Riverton and a trained avalanche instructor. Her husband, Keith, is an owner-operator and mechanic and we really enjoyed their company.

For next year, we will have two Owner-Operator Snowmobile Conferences, the first one will be at the end of January and the second one will be the end of February. I know most of you will not be able to attend both of them, however several of you will because it was your idea to get together twice a year to enjoy each other's company and ride snowmobiles together.

Written by: Bruce Mallinson and John Walko, Pittsburgh Power Inc., 3600 South Noah Dr. Saxonburg, PA 16056. Phone 724-360-4080

The new programs we have developed for the 2008 and newer ISX Cummins continue to impress us, with all of the emissions intact, the horsepower to the rear wheels is 600, which is 705 flywheel horsepower, and the torque is 2150 pound feet. This engine is compliant and you can take your truck into any truck or engine dealership and it will pass the emissions. We currently have four of the ISX Engines running with this tune, and the emission related problems have diminished. We feel that we will need to do an emissions tune up about every 250,000 miles and



**SEE YOU IN LOUISVILLE!**  
Booth Number 69212



**724-360-4080**



#BurghPower



#BurghPower



www.Facebook.com/BurghPower

Insured - Licensed Since 1979

**Snowflake**  
ESCORT FLAG CAR SERVICE

Harriet MacAvoy  
Youngstown, OH

Office	Cell	Fax
330-793-7024	330-550-1297	330-793-7715

Available Anywhere, Anytime - Long or Short Distance

**Fleet-Air FILTERS**

High Flow Washable Air Filters  
**Save Fuel and Filter Expense**

Endorsed by: "AJ" • Kevin Rutherford • Bruce Mallinson

- Washable foam filter media
- Increases air flow, lowers exhaust temperature
- Improves performance and fuel mileage.

6220 Theodore - Dawes Road, Theodore Alabama 36582  
**251-654-0892**  
Dealers visit our web site at [www.fleet-airfilters.com](http://www.fleet-airfilters.com)

MADE IN AMERICA

## SLC Lighting: The Lighting Basics: Why Can I Not Find Replacement Lights?

By Warren Lantz

If you own an older truck or one with new aftermarket LED lights installed, it can be frustrating to find a replacement for a failing unit. Especially if the truck you need the lights for is on the road every day. While I am not providing outright solutions, I will try to "clean up the waters" when it comes to explaining as to why you may be unable to find a replacement light.

Here are five things to keep in mind about the lighting industry.

- **A company discontinued a certain light.** This is the most common reason. The lighting industry's needs change rapidly, standards are raised, or it is no longer cost-effective. The end result being products become obsolete.

- **A company went out of busi-**

ness. Competition comes and goes. Typically, when a company goes under, they will sell their old stock to another business to resell for a limited time. Another company could also purchase the assets of that company to produce the same light under a different brand.

- **A company doesn't sell aftermarket.** Some exclusively sell their products to OEM manufacturers. This can result in specific lights being over-priced or hard to find an identical match. This is where the aftermarket light manufacturers come into play, to fulfil that niche.

- **One company manufactures that light.** A company may either have exclusive legal rights to manufacture a product or the demand is so small that other manufactures

decided not to produce the product at all.

- **One truck uses that light.** A fine example is a vintage International Eagle. The stacked headlights on that truck are not installed on any other model. We happen to offer replacements for those.

We carry some other sought-after products in the lighting industry. Visit our website [www.slclighting.com](http://www.slclighting.com) or you can give us a call at 800-938-0120 to see what we have to offer. Online, use the code MOVINOUT2016 or call in and mention that you saw our ad in Movin' Out for a 10% discount.

Next month, I will be busting myths and addressing common misconceptions about why one light may be brighter than another.

## Understanding Oil Contaminants



By Tom Bock

"Oil is cheap, compared to engine replacements". "My father and grandfather always changed their oil every 10,000 miles". "My mechanic has been in the business for 30 years and he says the OEM filters are all I need". "Oil sampling is a waste of my money". "Bypass filters are nothing more than a roll of toilet paper in a tube". "Oil can't possibly last over 100,000 miles". These are just a few of the oil myths I hear when I explain how a good oil maintenance program should include a quality Bypass or On-Board Oil Refining System and periodic oil sampling.

These myths may have some validity to some people who live in the past when engines did not have the tighter tolerances and were not subject to the additional stress of EGR systems and twin turbo chargers that are being used today.

The newer engines have tolerances that keep engines tighter and able to go over 1,000,000 miles before requiring rebuilding if oil is properly cleaned removing the small particles, that get trapped between the moving parts and wear them down. The OEM filters are designed to filter particles over 40 microns in most engines. They do not filter the particles under 10-20

microns that cause the majority of the wear as they become trapped between piston rings and cylinder walls or bearing and shafts.

I am fairly certain engines built back when your grandfather and father bought their first trucks the engines were not subject to the stresses of the EGR systems that add soot and debris back in to the oil that must be removed to prevent wear damage. The newer oils while no long "cheap" have been formulated to keep these particles in suspension but they do not prevent them from grinding away at moving parts. Couple this with the additional heat generated by the turbo chargers used today and you can only benefit by utilizing the additional filtration of a Bypass or On Board Oil Refining System.

Changing your oil on a periodic cycle i.e. every 10- 15000 miles subjects your engine to function in a cycle of clean oil that becomes contaminated overtime slowly damaging your engine only to start again when you change oil. If your selected interval passes the point whereby the oil is no longer effective you subject the engine to additional pitting by acids, wear by particulates and failure from loss of oil pressure. If you change the oil too frequently you waste \$\$\$ on oil. It is much better to keep the oil clean and free of particulates and acids, allowing your engine to run with clean oil all the time. The Bypass and On-Board Oil Refining Systems on the market today have proven that over time your engine will last longer if filter out the damage causing particulates and control acid formation.

As I stated above the oil myths may have some validity but ask yourself this? How often did engines require rebuilding when oil was cheap and oil was changed instead of being cleaned continuously? What tolerances did engines have when my mechanic started 30 years ago and what benefit would he have in my engine running the clean-contaminated-clean cycle compared to running with clean oil continuously? When I dump my oil without sampling how do I know if my engine has antifreeze or fuel leaking in to my oil or if an engine part is wearing abnormally? Is taking oil samples whether you use a Bypass or On-Board Oil Refining System that identify small problems before they become big costly problems, worth the cost of oil sample?

If you have any questions or topic suggestions for this column email me at : [tbock@ops-1.com](mailto:tbock@ops-1.com)

**Advertise to 500,000 Homes** with a business card size ad. You choose the area of coverage in free community papers...we do the rest. Call 800-450-7227 or visit [macnetonline.com](http://macnetonline.com)

---  
**Experienced OTR van drivers wanted** for trips originating out of WI & delivering to the North East. Avg 2700-3000 miles/week. Home Weekends. Pd vacation, 401k, vision, dental, disability & health insurance. Class A CDL, 2 yrs OTR experience, good MVR, references required. Online application @ [titrucking.com](http://titrucking.com) or Call Ruth/Mike 1-800-222-5732

---

**The Mid-America Trucking Show: Louisville, KY - Booth # 74120**

OEM and AFTERMARKET  
**LIGHTING PRODUCTS**

[www.slclighting.com](http://www.slclighting.com) VIEW OUR FULL CATALOG ONLINE

101 Parker Drive Andover, OH 44003  
Tel: 800-938-0120 [orderdesk@slclighting.com](mailto:orderdesk@slclighting.com)

Visit RoadWorks Mfg at the 2016 Mid-America Trucking Show!

March 31 - April 2, at the Kentucky Exposition Center in Louisville, Ky.

Stop by booth 12240 to see us and pick up your copy of the 2016 RoadWorks Catalog!

Follow us at: [www.facebook.com/roadworks.manufacturing](http://www.facebook.com/roadworks.manufacturing)

To learn about RoadWorks Stainless Steel Products or to request a catalog, call RoadWorks Customer Service at 1-800-448-8741, or visit our website at [www.roadworksmfg.com](http://www.roadworksmfg.com).

# Change Your Thinking Not Your Oil™

## Cut Oil Maintenance Costs by 80%

### With Oil Purification Systems

- Effectively removes solid and liquid contaminants.
- Extends Engine life by running clean oil through your engine 100% of the time.
- Safely extends oil change intervals using OPS TRU-TEST fluid analysis. Also provides engine wear analysis.
- Flexible configuration to meet your protection needs.
- Return on investment in as little as 8 months.

**Endorsed By:**  
Kevin Rutherford - Trucking Business & Beyond  
Bruce Mallinson - Pittsburgh Power

The right size solution for your business needs  
**ecopur**

**Reduce Your Truck's Environmental Impact!**

**OPS** Oil Purification Systems  
**866-Oil-Pure** (866-645-7873)  
[www.ops-1.com](http://www.ops-1.com)

Find us on Facebook Keyword Oil Purification Systems inc.

**SEE US AT M.A.T.S. BOOTH #68216**

**BUILT ON HONESTY AND INTEGRITY!**



**Leasing Owner-Operators**

- Well-maintained equipment
- Family-oriented environment
- No Touch Truckload Freight

Main Customer Locations   
 Service Area 

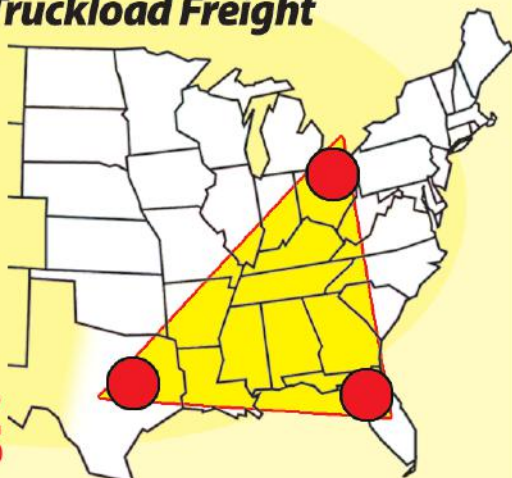

Learn more. Call today.  
**888-678-6055**

**ATA Truck Tonnage Index Slides 1.4% in January**

Arlington, VA... American Trucking Associations' advanced seasonally adjusted For-Hire Truck Tonnage Index fell 1.4% in January, following no change during December. In January, the index equaled 132.8 (2000=100), down from 134.7 in December, an all-time high (along with November 2015).

Compared with January 2015, the SA index was flat, which was down from December's 0.8% year-over-year gain. For all of 2015, compared with 2014, tonnage was up 2.6%.

ATA recently revised the seasonally adjusted index back five years as part of its annual revision.

The not seasonally adjusted index, which represents the change

in tonnage actually hauled by the fleets before any seasonal adjustment, equaled 127.1 in January, which was 5.2% below the previous month (134.1).

"Clearly, 2016 started soft for truck tonnage," said ATA Chief Economist Bob Costello. "There was a deceleration in freight volumes during the second half of 2015 which continued into the first month of 2016.

"The winter storms that hit in January likely suppressed volumes some, but by falling 1.4%, I doubt tonnage would have been positive without the storms. So, that tells me that the inventory situation continues to weigh on truck freight volumes. The sooner the supply chain cleans out the excess stocks,

the better for trucking," he said. Trucking serves as a barometer of the U.S. economy, representing 68.8% of tonnage carried by all modes of domestic freight transportation, including manufactured and retail goods. Trucks hauled just under 10 billion tons of freight in 2014. Motor carriers collected \$700.4 billion, or 80.3% of total revenue earned by all transport modes.

ATA calculates the tonnage index based on surveys from its membership and has been doing so since the 1970s. This is a preliminary figure and subject to change in the final report issued around the 10th day of the month. The report includes month-to-month and year-over-year results, relevant economic comparisons and key financial indicators.

**SEMI-DUMP OWNER OPERATORS**  
**High Earning Potential**

- Full time year round work
- Best Semi-Dump Freight and Rates in the industry both industrial and hazardous
- 100% Fuel Surcharges paid up front
- Contractors welcome with Hazmat Endorsement or without



**U.S. BULK TRANSPORT, Inc.**  
**800.642.8910**  
 usbulktransport.com

We have the largest network of terminals and Logistics Offices in the Semi-Dump industry.



• Terminal Locations

**See us at M.A.T.S. Booth # 68032**



**New Pay Structure ...**

**Flat Rate, Paid Tolls, Increased Rate For Unloaded Miles ...**

FedEx Custom Critical is introducing a new flat rate compensation plan for owner-operators. We are seeking teams with high quality standards and a drive to succeed.

- Tolls paid on ALL authorized miles\*
- Pay for ALL authorized unloaded miles, starting at mile one
- Fuel surcharge paid on ALL authorized miles
- Extra compensation for hazmat loads
- Extra compensation for Canadian and New York City loads<sup>‡</sup>



**Call 1.888.444.7194**

You can also learn more online by visiting [customcritical.fedex.com/us/owneroperator](http://customcritical.fedex.com/us/owneroperator)

\*Tolls: FedEx Custom Critical will provide tolls assistance on authorized loaded miles and authorized deadhead to pickup miles. (We will not pay tolls on deadhead to planned layover miles) Mileage is based on PC Miller in the version currently used by FedEx Custom Critical.  
<sup>‡</sup>Anytime you cross the Canadian border loaded (whether going into or out of Canada), you will receive an additional fee and anytime you pick up or deliver in the five boroughs of New York, you will receive an additional fee. However, you can only receive this fee once per shipment.

**Load Statement**

**FedEx Custom Critical**

- Tolls assistance on all authorized miles\* 
- Pay for ALL authorized unloaded miles starting at mile one 
- Extra pay for NYC and Canada loads 
- Extra pay for taking hazmat loads 



# The Circuit Rider



Robert E. Harris, "The Circuit Rider" was the nation's last practicing circuit riding preacher until his death in 2007. His ministry took him to numerous towns throughout western North Carolina as well as rest areas along I-40. His ministry and legacy continues through the Robert E. Harris Evangelistic Association, Inc., P. O. Box 67, Asheville, NC 28802.

## ATA: "Driver Rest Break Fix Would Ensure Uniform Safety Rules Nationwide"

Arlington, VA... American Trucking Associations leaders called on Congress to reject efforts by organized labor and trial attorneys that would impose a patchwork of state scheduling rules on the nation's foremost movers of goods.

Language in the Federal Aviation Administration Authorization Act of 1994 made it clear states are not permitted to institute rules governing the trucking industry because Congress wanted the industry to operate under a single, uniform system from coast-to-coast rather than a confusing and inefficient patchwork of state laws. However, some states - notably California - a handful of courts, and aggressive plaintiffs' attorneys are refusing to faithfully uphold that goal of one country, one set of rules.

ATA also chided opponents of this measure for being deceptive in their characterization of the provision's impacts.

Since the 1930s, the federal government has maintained a uniform national set of work and rest rules for the trucking industry that has been imperiled by recent court actions. ATA calls upon Congress to safeguard these important regulations.

Switch to DIRECTV and get a \$100 Gift Card. FREE Whole-Home Genie HD/DVR upgrade. Starting at \$19.99/mo. New Customers Only. Don't settle for cable. Call Now 800-530-1453

---  
**Holding a Carnival! Fair! Festival! Jubilee!** Promote it to over 1 Million readers for only \$200!!! Visit [www.midatlanticevents.net](http://www.midatlanticevents.net) for more details or call 800-450-7227.



## Rocky's Truck Body Shop

**"COLLISION IS OUR SPECIALTY"**

• *Painting* • *Insurance Claims* • *Major & Minor*  
I-80 + SR 62 + 7 Next to Truckworld  
2325 N. Main St., Hubbard, Ohio (330) 534-7743  
[www.rockystruckbodyshop.net](http://www.rockystruckbodyshop.net)  
e-mail: rockyrocks75@aol.com

## Your Steps Should Lead In A Different Direction

A little boy was converted by reading the New Testament. One day his dog tore a page from his New Testament. The boy told his preacher about the dog eating the page, explaining that he was worried.

The preacher explained, "If that dog can other beasts and not be hurt, a page from the Bible won't hurt him either."

The child said, "When I read the Bible it made me love my enemies and forgive everyone. Now my dog will forgive all the wild beasts and be their friend."

Here was a very promising little boy. He was thinking for himself. It is positively true that old time religion changes the nature of men. The Bible teaches, "If any made be in Christ, he is a new creature, old things are passed away. Behold all things are become new."

If you are a changed person and your life now has a different tin and your steps lead in a different direction, then you can say, "I'm following Christ."

Lexington Intermodal, LLC  
Madison Intermodal, LLC

**WALL STREET SYSTEMS**



and affiliate companies.

Park Ave Intermodal, LLC  
Wallstreet Intermodal, LLC  
Broadway Intermodal, LLC

Intermodal Drivers and O/O wanted now for leasing in all port cities and rail ramps in North and Southeast.

Agent opportunities, Please call Reggie Whisnant at:  
**216-536-9195**  
or **704-628-6047**

### Corporate Office

3329 Frost Rd. • PO Box 847 • Mantua, Ohio 44255  
**online Apps: [www.wallstreetsystemsinc.com](http://www.wallstreetsystemsinc.com)**

- Lease purchase option available to qualified drivers
- Great compensation Package
- Comprehensive plate program
- Driver Incentives
- Fuel discounts at most major Truckstops

Call our safety department at:  
**(800) 448-1775 ext. 221 • Ask for Molly**

**ELLET RADIATOR SERVICE INC.**  
2802 Albrecht Ave. Akron, Ohio (Minutes from I-76)  
**330-784-8226**  
[www.ElletRadiator.com](http://www.ElletRadiator.com)

**SPECIALISTS IN COMMERCIAL AND HEAVY EQUIPMENT RADIATORS.**

**New in Stock**  
Radiators • Charge Air Coolers  
AC Condensers • EGR Coolers • DPF Filters

**NOW TESTING & CLEANING DIESEL PARTICULATE FILTERS**

Cleaning • Repairing • Recoring  
Fuel Tank Repair • Aluminum & Steel Welding

## 18<sup>TH</sup> ANNUAL TRUCK SHOW

# 75 CHROME SHOP

# Pride & Polish

Visit [75chromeshop.com](http://75chromeshop.com) for more information or to enter the competition.



**Wash & Show**

THIS YEAR, THE 75 CHROME SHOW WILL HOLD A SEPARATE CATEGORY FOR EVERYDAY TRUCK DRIVERS TO SHOW OFF THEIR TRUCKS. TRUCKS MUST BE CLEAN FOR PRESENTATION AT TIME OF JUDGING (EXTERIOR JUDGING ONLY). WASH SERVICES LOCATED ACROSS THE STREET AT WILDWOOD TRUCK/RV WASH.

**EVERYONE WELCOME!**

<p><b>Fri., April 22nd</b> 9am - 6pm Contestant Parking and check-in 6pm Drivers meeting NO Spectator Events Friday</p>	<p><b>Sat., April 23rd</b> 9:00 am Rags Down - Show Opens 9:30 am Judging Begins Dusk Light Show Entertainment, Food and Vendors</p>	<p><b>Sun., April 24th</b> 10:00 am Award Ceremony Sunday Afternoon Trucks Depart</p>
---	--	---

**LOCATED AT I-75 (EXIT 329) & SR 44 WILDWOOD**  
[75chromeshop.com](http://75chromeshop.com) • 352.748.0330

# TICKETS

We Win 9 out of 10 Cases!

*Espanol - Lucy*  
*Russian - Alena*  
*Korean - Jessica*

**28 Years Fighting for the Trucker!**

**I-800-525-HAUL**

**NATIONWIDE**

**CANADA**



Company Programs

**CSA/DAC HELP**

24 hrs (7days a week)

**All Legal Problems**

[www.AmericanTruckersLegalAssoc.com](http://www.AmericanTruckersLegalAssoc.com)

\* Past performance of attorneys who represent ATLA members does not guarantee future performance.

# Mawson And Mawson - We Want YOU!

Mawson and Mawson, America's oldest carrier (MC #76) is proud to offer employment opportunities to our nation's veterans. We are currently looking for veterans with a military transportation background and will train them to do flatbed work. Mawson and Mawson has a long history of hiring former military personnel. Servicemen and women are hard workers and natural leaders — making for valuable employees.

Veteran and Company Driver, Charles 'Sarge' McNaughton has been driving for Mawson and Mawson for the past four years. Prior to joining the company, Sarge served 11 years active duty in the U.S. Army, along with 25 years in the National Guard and Army Reserve. He was a Motor Sergeant, Maintenance Supervisor, Truck Driver and Instructor retired from the PA National Guard.

Sarge says the instruction he received in the Army was very interesting; and the transition from military to civilian hauling was a smooth one. He already had experience with chains and binders, but just needed to apply his training to steel coils and other products.

After driving for three years, he is now a trainer as well as a company driver at Mawson and Mawson. Chuck McNaughton likes the change of pace and meeting new drivers. After a driver has completed his training, Sarge makes himself available for future help or advice. Mawson and Mawson takes great pride in offering an opportunity to

veterans when they return home from serving our country. Sarge was given a chance when others turned him away. He took that chance and turned it into a career he is proud of. McNaughton says, "If you want to drive for a good company, we're here. It's been great for me, so come on over."

Company Drivers and Independent Contractors joining the Mawson Team will receive a \$1,000 sign-on bonus.

Recognized as one of the preeminent players in the flatbed transportation industry, we proceed into the new millennium with a firm foundation built on honesty and integrity. Our courteous, experienced staff will work with you from your initial contact, to orientation, to quickly getting you out on the road and making money.

If you would like to join our winning team, please call us 800-262-9766 or visit us on the web at: [www.mawsonandmawson.com](http://www.mawsonandmawson.com)

...Welcome home and Thank You for your service!

**MOUNTAINTOP FARM!** 5 acres - \$34,900 Jaw dropping views, fields, stonewalls, southern exposure, less than 3 hrs from the GW Bridge! (866) 495-8733 [NewYorkLandscapeLakes.com](http://NewYorkLandscapeLakes.com)

---  
**LENDER ORDERED SALE!**  
**CATSKILL MTNS!** 39 acres - \$119,900 Fields, woods, apple trees, valley views, stonewalls, ATV trails! 3 hrs NY City! Terms avail. Call (888) 738-6994 [NewYorkLandscapeLakes.com](http://NewYorkLandscapeLakes.com)

# Goodyear Expands Commercial Tire & Service Network



1102 Walker Street (off Interstate 80, exit 284) and contains three drive-through bays.

The Eloy Goodyear Commercial Tire & Service Center at 649 South Sunshine Blvd. features three drive-through bays and is located behind a Pilot Flying J Travel Plaza, off Interstate 10, exit 208.

All five locations offer new Goodyear truck tires, Goodyear retreads and 24/7 Goodyear-Fleet HQ Emergency Roadside Service, which has helped more than 1.1 million trucks return to service.

The South Beloit, Walcott and Eloy Goodyear Commercial Tire & Service Centers also offer DOT inspections, oil changes and light mechanical work.

Goodyear offers The Total Solution of trusted products, reliable services, business solutions and a nationwide network to help commercial trucking fleets lower their total cost of ownership. To learn more, visit [www.goodyeartrucktires.com](http://www.goodyeartrucktires.com). For more information about Goodyear Commercial Tire & Service Centers, go to [www.goodyearctsc.com](http://www.goodyearctsc.com).

**Safe Step Walk-In Tub Alert for Seniors.** Bathroom falls can be fatal. Approved by Arthritis Foundation. Therapeutic Jets. Less Than 4 Inch Step-In. Wide Door. Anti-Slip Floors. American Made. Installation Included. Call 1-800-906-3115 for \$750 Off  
Repeat ad from 1/17/2016

AKRON, OH... An important part of the Goodyear Total Solution for fleets, the Goodyear Commercial Tire & Service Network continues to grow.

Goodyear recently opened Goodyear Commercial Tire & Service Centers in the following cities: Portage, Ind.; University Park, Ill.; South Beloit, Ill.; Walcott, Iowa; and Eloy, Ariz.

The Portage Goodyear Commercial Tire & Service Center spans 4,800 square feet, has one service bay and is located at 6791 Melton Rd. The 11,200-square-foot University Park Goodyear Commercial Tire & Service Center has three drive-through service bays and is located at 1265 Hamilton Ave., Suite 100, off Interstate 57, exit 335.

The South Beloit Goodyear Commercial Tire & Service Center at 16067 Willowbrook Road spans 10,300 square feet, has three service bays and is located behind the Pilot Flying J Travel Plaza, off

Interstate 90, exit 1.

The 10,300-square-foot Walcott Goodyear Commercial Tire & Service Center is located behind a Pilot Flying J Travel Plaza at

**4 STATE Trucks.com** AFTER 30 YEARS THE USED PARTS DEPARTMENT IS COMING TO AN END!

**SALVAGE LIQUIDATION SALE**

**DON'T MISS IT!**

**THURSDAY, APRIL 21 AND FRIDAY, APRIL 22**

**Blackmon**

CONTACT 501-664-4526  
FULL SALE CATALOG AVAILABLE IN APRIL AT [WWW.BLACKMONAUCTIONS.COM](http://WWW.BLACKMONAUCTIONS.COM)

VISIT OUR NEW EXPANDED LINE OF NEW AFTERMARKET TRUCK AND TRAILER PARTS AT [WWW.4STATETRUCKS.COM](http://WWW.4STATETRUCKS.COM) OR CALL US AT 800.228.1103

CHECK OUR FB PAGE FOR MORE INFO!  
4579 HIGHWAY 43, JOPLIN, MO 64804

**Oldest Class 1 Carrier in America.**  
ICC #76

**Mawson and Mawson, Inc.**  
[www.MawsonandMawson.com](http://www.MawsonandMawson.com)

Like Us On facebook

Celebrating **120 YEARS**

**\$1000.00 SIGN-ON TO ALL DRIVERS!**

## All-Driver Incentives

- First-In/First-Out
- Most Weekends Home
- Free Electronic Bill Scanning
- Weekly Settlements/ Direct Deposit
- Pre-Pass
- Reitnauer® Trailers Available

## Independent Contractors

- No Forced Dispatch
- Up to 78% Gross From 100%
- All State Road & Fuel Tax Paid By Us.
- Occupational Accident Available
- Bobtail, Collision, Plates Available

## Company Drivers

- New Equipment
- Compensation Based on Experience
- Excellent Medical Coverage
- Matching 401K Plan
- Paid Vacation

## Requirements

- Must Be 25yrs of Age
- Must Have a Valid Class A CDL
- Must Have Current DOT Physical
- Must Have 2yrs Over-The-Road Tractor Trailer Experience
- Paid Training Available for Non-Steel Haulers

Call  
**Recruiting at**  
**800-262-9766**

# DRIVERS ARE UNSUNG HEROES

they are often over looked, and not thanked enough for the tough work they do to keep our country moving. We have seen much in our 20 years in the industry, but one thing is constant, and that is the importance of quality drivers that take pride in the work they do. We at JK Hackl wanted to take a moment to thank not just our drivers, but all drivers. From all of us at JK Hackl.

**Thank You.**

**NOW HIRING** EXPERIENCED FLATBED AND SPECIALIZED TRUCK DRIVERS TO JOIN OUR COMPANY.

- Average over 60K
- Free Dental and Vision Insurance
- APU's \*Pet and Rider Policy \*PrePass
- Plus \*Direct Deposit and much more
- \*see [www.jkhackl.com](http://www.jkhackl.com) for complete details

**\$2,500 sign-on bonus**

Affordable Comprehensive Health Insurance



"Driven to be the best-by-the-best"

**(800)-669-2625**

[www.jkhackl.com](http://www.jkhackl.com)

call between 7am and 6pm CST Monday through Friday

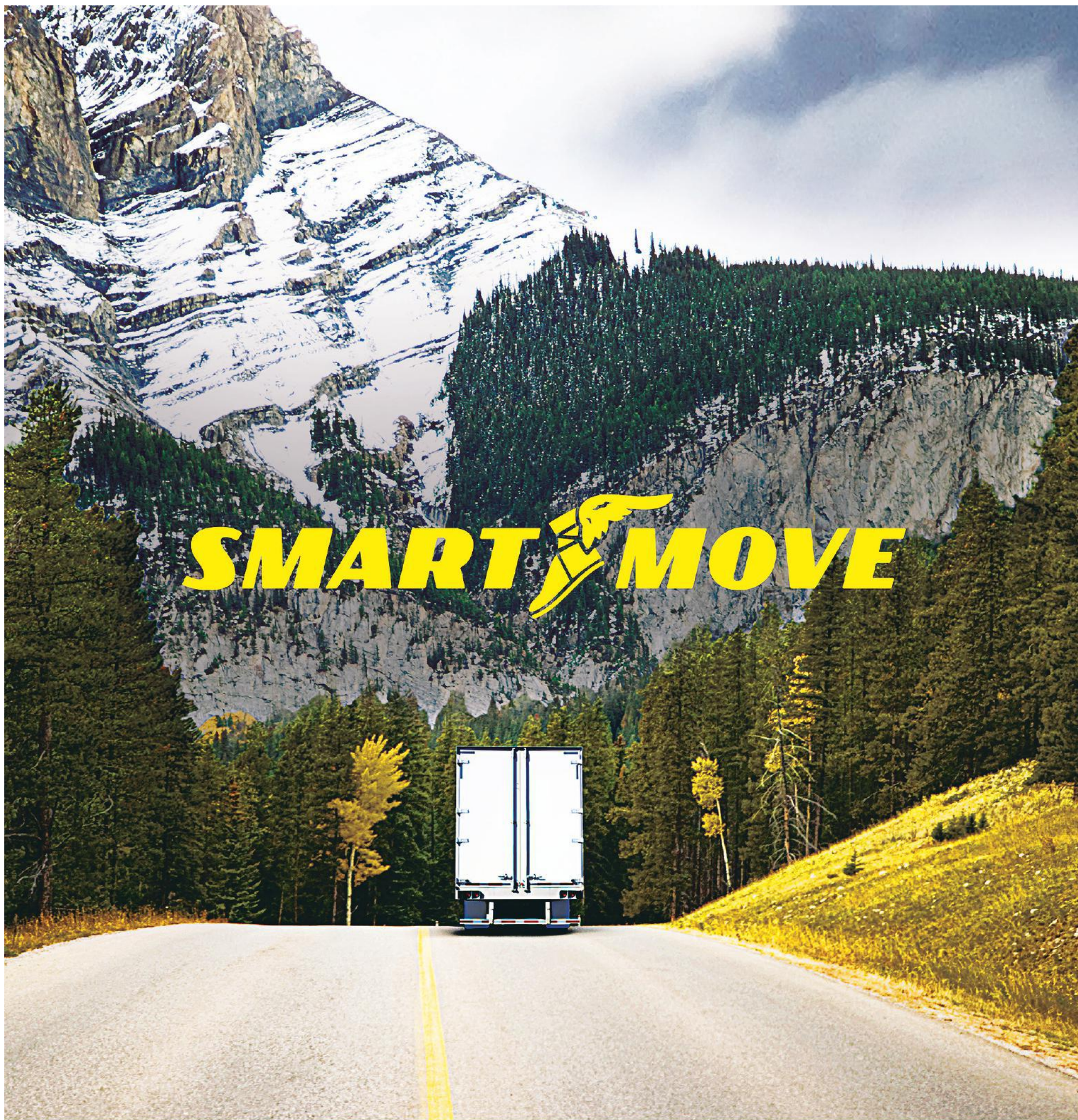

# SMART MOVE

GET UP TO  
**\$250** BY MAIL-IN  
REBATE\*

When you join Goodyear® Smart Fleet, the national account program for owners/operators and small fleets (\$25 per tire, limit 10 tires).

### Goodyear Smart Fleet Helps You Compete With Fleets 10 Times Your Size!

- Published prices on tires and exclusive promotions
- 24/7 Roadside Assistance with no dispatch fee
- 2,300+ authorized dealers ready to help your fleet

For more information call 1-888-888-8687. Or, join today by visiting [goodyearsmartfleet.com](http://goodyearsmartfleet.com).

### Make Goodyear Smart Fleet Part Of Your Total Solution



Trusted Products



Nationwide Dealer Network



24/7 Reliable Services



Fleet Management Tools

\*Rebate valid on purchase of 10 qualifying Goodyear tires. Offer valid 120 days after you submit application. See rebate form for complete details.

©2016 The Goodyear Tire & Rubber Company. All rights reserved.



## NOW LEASING OWNER-OPERATORS!

Become part of Unigroup Logistics



**Special Commodities/Truckload** - Air-ride vans ensure safe and dependable delivery at all times for telecommunications equipment, store displays, hospital equipment and more.

**LTL Electronics** - everything from delicate electronic equipment to antiques and collectibles.

**Climate** - high end electronics, artwork, and museum logistics.

**Aerospace/Oversize** - handle one-of-a-kind items, from antennas to satellite systems to rocket engines.

**Household goods** - the natural choice for family relocation, whether it's a local or cross country move.

**Owner Operators** - are growing with the expansion of our **Lease Purchase Program** and driver support.

**Enclosed Auto Transport** - Handling Classic, antique, exotic, muscle cars and more.

### THE McCOLLISTER'S DIFFERENCE:

Incredible home time • Keep 100% of fuel surcharge

58-75% truckload slots • Weekly Settlements

**TEAM OPPORTUNITIES**



For more information, call Joe Csik at 1-800-257-9595 ext. 9490

Learn more about McCollister's Transportation Group, Inc. at [www.mccollisters.com](http://www.mccollisters.com)

# McCollister's Auto Transport

Enclosed Transport Fleet

Specialized Enclosed Transportation for

## All Types of Automobiles

OPPORTUNITIES AVAILABLE FOR

Experienced Drivers

Owner Operators

Lease Purchase • Company Drivers



For more information, call Joe Csik at 1-800-257-9595 ext. 9490

[www.mccollisters.com](http://www.mccollisters.com)

# KENWORTH

KENWORTH OF PENNSYLVANIA

## TRP® ALUMINUM WHEEL SALE



Aluminum wheel, 22.5" x 8.25", semi polish

AW2258MN

**\$252.99**

each\*

Aluminum wheel, 24.5" x 8.25", semi polish

AW2458MN

**\$273.99**

each\*



\*With your Kenworth privileges Card. Offer code Y1656

Sale begins 4/01/16

Sale ends 4/30/16

[www.kwofpa.com](http://www.kwofpa.com)

Carlisle	(717) 766-8000	Shartlesville	(610) 488-1660
New Stanton	(724) 925-5000	Pittsburgh	(412) 778-0160
Dunmore	(570) 347-5671	York	(717) 848-8797
Clintonville	(814) 385-1040	Lancaster	(717) 898-2650

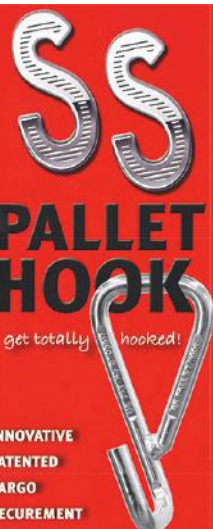

#### Advantages of the SS Pallet Hook:

- Carrier Benefits**
  - Shows customers you value their products
  - Helps with freight claim disputes
  - Can eliminate freight claims
  - Reduce WC claims
  - Save money!
  - Driver retention
- Driver Benefits**
  - Easy to use and easy to carry
  - Hooks up quickly
  - SAFE - Installs and removes while pallet is in place
  - Many uses for cargo control
  - Keeps freight from shifting, tipping or falling
  - Drivers save time; time is money!
  - Less missed appointments due to restacking
  - Saves time not looking for additional dunnage
  - Gives drivers peace of mind that freight won't shift
  - Drivers gain a sense of pride
  - Drivers can safely stagger freight for pick-ups and deliveries to save time and miles.

Cargo Strategies LLC

[www.cargostrategies.com](http://www.cargostrategies.com)

[info@cargostrategies.com](mailto:info@cargostrategies.com)

608-963-8330

MARCH 31 - APRIL 2, 2016  
LOUISVILLE, KENTUCKY  
2016 MID-AMERICA TRUCKING SHOW  
VISIT US IN BOOTH 66101



**NEW CASTLE  
TRUCK**

"Maximum Performance with Minimum Downtime"

## COLLISION REPAIR PAINTING & FABRICATING

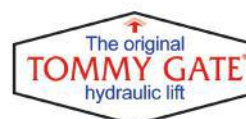

3008 New Butler Road • Rt. 422, New Castle, PA 16101

Nationwide On Your Side Truck and RV Network Facility

PH: 724-924-1649 • FX: 724-924-1659

[www.newcastletruck.com](http://www.newcastletruck.com)

PROGRESSIVE Commercial Authorized Network Repair Center

PROGRESSIVE Commercial Authorized Network Repair Center

## Dana Announces Next-Generation Driveshaft Optimized for Engine Downspeeding with Advanced, Lightweight Design

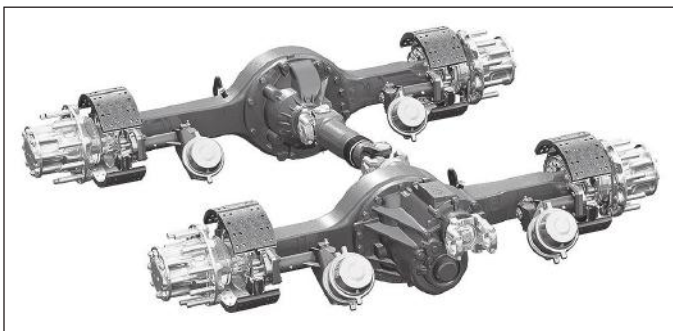

NASHVILLE, TN... Dana Holding Corporation announced a new driveshaft specifically engineered to further support engine downspeeding. Dana's next-generation driveshaft weighs 30 pounds less than existing products and is tailored to address the specific torque-management strategies of individual commercial-vehicle manufacturers.

Engineered with fewer components, this next-generation driveshaft offers a simplified installation process to reduce assembly costs for original-equipment manufacturers (OEMs) and improve ease of maintenance for truck owners. Performance and vehicle dynamics are improved with reduced noise, vibration, and harshness levels, which can also extend component life. Available now for pre-production evaluation by OEMs, Dana's latest innovation is designed for severe-duty, long-haul applications on high-efficiency Class 8 trucks. This driveshaft is ready for powertrains of the future that will be engineered for further engine downspeeding – enabling an axle ratio lower than 2.26:1, which is the fastest ratio on the market today.

"Engine downspeeding is not a one-size-fits-all solution. Each OEM implements this efficiency-boosting strategy in its own way, resulting in very specific torque-handling requirements," said Mark Wallace, executive vice president of Dana and group president of Dana On-Highway Driveline Technologies. "This next-generation driveshaft is the result of our continuous drive to deliver flexible solutions to meet each customer's unique needs while further reducing weight and improving efficiency in our products."

Dana was the first to offer a driveline solution for engine downspeeding with the introduction two years ago of the Spicer® AdvanTEK® 40 tandem axle, SPL®350 driveshaft, and SPL® 250 inter-axle shaft. Together, this system can handle 30 percent higher input torque from downsped engines, and it enables increased overall vehicle efficiency of more than 2 percent when compared with competitors' offerings.

For more information about Dana's downspeeding package for commercial vehicles, visit [danacy.com/daretocompare-downspeeding](http://danacy.com/daretocompare-downspeeding).

**SEE US AT M.A.T.S BOOTH #'S 19028 & 69057**

**The Fuel Mileage Doctor inc.**

WITH BULLY DOG  
**BIG RIG PRODUCTS**  
THAT RAISE THE BAR ON QUALITY

**CHECK OUT OUR NEW HD TURBO**



**MANIFOLDS**

- Flow tested for maximum efficiency
- Proven mileage gains
- Spool turbo quicker



**TUNERS**

- Fuel mileage tested in real time with Taylor fuel monitoring equipment
- Tested for your engine's safety
- Power tuning that excites



**CAT®**

- New BILLET intake wheel
- Upgraded clamps
- No core charge
- 36 HP gain

**Visit US TODAY**

**Kevin Campbell**  
Kevin@fuelmileagedr.com  
717-320-2259 | Eldred, PA 16731

**WWW.FUELMILEAGEDR.COM**



**BIG RIG BULLY DOG**  
powered by DERIVE  
PROVEN PERFORMANCE



*We Carry Through*



**2011 - 2013 Volvo VNL64T670,  
Volvo D13, 475 h.p., 10 spd. or  
I shift, air ride susp., all aluminum.**

**Starting at \$39,900!**

**MANY CLEAN UNITS TO CHOOSE FROM!**



**Call Now! (877) 269-6261**

**Seeking Flatbed, Step Deck, RGN  
Owner Operators and Fleet Owners!**



**\$1,000 SIGN ON BONUS!**

Operate in all 48 states / No Forced Dispatch  
50% Advance and Same Day Pay  
No Upfront Fees / No Escrow or Money Down  
75% of 100% line haul with 100% fuel and accessorial charges

**Lease on with Packard Transport!**

APPLY NOW at [www.packardtransport.com](http://www.packardtransport.com)  
Call Recruiting at 800 955 6369



Requirements:  
25 years of age  
Valid Class A CDL  
3 years OTR experience  
Well-Maintained equipment

Visit us at MATS  
Booth #64012

## CAT Scale's Weigh My Truck™ App Now Accepting the Comdata Card for Payments

WALCOTT, IA... CAT Scale Company is pleased to announce that its very popular Weigh My Truck™ application has added the Comdata Card to its available payment methods.

The Weigh My Truck™ application allows drivers to weigh their truck and pay for the transaction all from their smartphone. Drivers can weigh and then get the weights displayed right on their phone without ever leaving the cab. The app will also email a PDF copy scale

ticket or weight information text file to up to five email addresses the driver specifies. If a driver needs a hard copy scale ticket, they can still pick up a printed CAT Scale ticket at the fuel desk within an hour after weighing using the Weigh My Truck™ application. Fleets have additional options available for driver enrollment and data receipt.

"We understand how valuable time is to a driver," says Delia Meier, Senior Vice President of CAT Scale Company. "Use of the Weigh My Truck app has proven to have a significant and positive impact on the driver's time. Having the Comdata Card available for payment within the app opens it up to an even greater number of CAT Scale customers, while still providing the fleets with confidence that their required controls and limits are in place."

Kelle's Transport Services, which operates more than 285 trucks and 400 reefer trailers from its headquarters in Salt Lake City, Utah, has been using the payment solution with Comdata for their CAT Scale transactions. "The time savings on the road have been invaluable," said Carrie Burbidge, fuel and permits manager at Kelle's. "Our drivers are easily saving 35 minutes or more for each transaction with this process."

More information about the new Weigh My Truck™ app can be found online at [www.weighmytruck.com](http://www.weighmytruck.com).

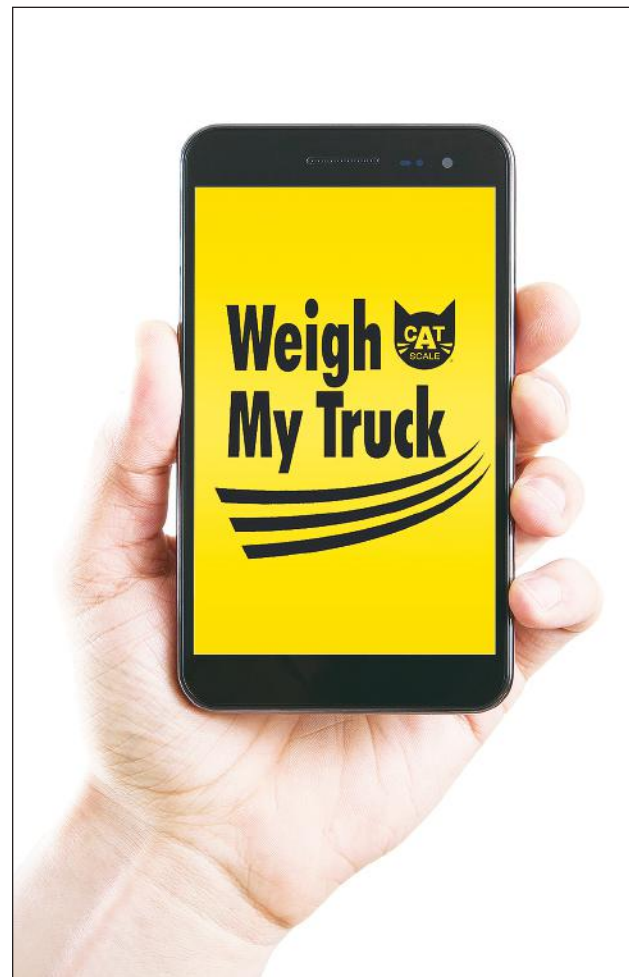

Weigh My Truck™ is available on the Google Play Store and also the Apple App Store.

CAT Scale Company is the world's leading truck scale network providing guaranteed, accurate weights at over 1,650 locations in the U.S. and Canada.

[www.weighmytruck.com](http://www.weighmytruck.com)

### • Owner/Operators

• **Average Gross Earning Of 125K-200K Annually**

• **Run Regionally In PA. NY. CT. MA. VT. NH. OH. IN.**

• **Specific Loads Available In PA., OH. and NY. - No NY City**

• **Pull Company Dry Vans • No Age Restrictions On Power Units**

- No Forced Dispatch • Drop and Hook - No Touch Freight • No Hazmat
- Percentages Paid on 100% of Gross • Plate Program • 100% Surcharge Paid on Every Load
- 4% Bonus for East Bound Lanes • Home Weekends • Fuel, Road Taxes and Permits Paid
- Bobtail, Collision, Occupational Accident and Buy Down Insurance Available
- ComData Fuel Card • Safety Bonuses and Awards
- No Escrow Deducted

**WARREN C. SAUERS Co, INC.**

Cranberry Township, PA

**(800) 245-1944 ext. 228**

[www.wcsauers.com](http://www.wcsauers.com)

**Call Today!**



# WE NEVER REST



**24/7/365**

CAT Scale is the largest truck scale network in the world and growing all the time. With more than 1,650 locations in the United States and Canada, there's always a CAT Scale open when you need one. Professional drivers know that CAT Scale delivers a reliable, accurate, certified weigh with an unconditional guarantee.

**IT'S THE BEST WAY TO WEIGH!**

Download the **Weigh My Truck** App.  
It's the fastest way to weigh!

1-877-CAT-SCALE (228-7225)

[catscale.com](http://catscale.com) | [weighmytruck.com](http://weighmytruck.com)



**ELW Co.**  
[www.elwcompany.com](http://www.elwcompany.com)  
Your Truck Repair Specialists.

**BEST APU PRICES IN THE COUNTRY!**

**COMFORTPRO**

**FINANCING AVAILABLE**  
**614-871-1620**  
Selling and servicing APU's since 1995.

**Hess Auctioneers**  
1-866-511-2493  
1000 BROADWAY, MARIETTA, PA 15757

CONSIGNMENT & LIQUIDATION

**TRUCK/TRAILER/EQUIPMENT AUCTION**  
**Friday, April 15th**  
**8:30 AM**  
**Marietta, PA**

Call to Add Items to this Auction!

**ONLINE & ONSITE BIDDING!**

Construction Equipment, Ag & Material  
Handling Equip  
Sleepers, Daycabs, Dumps, Straight Trucks  
Flat/Van/Reefer Trailers,  
Pickups, Cars, RVs, ATVs

[www.HessAuctioneers.net](http://www.HessAuctioneers.net)

Call Today! 1-866-511-2493  
Email: [Sales@HessAuctioneers.com](mailto:Sales@HessAuctioneers.com)  
Auction Site: 1451 River Rd. Marietta, PA 17547  
PA Auction Co. # AY2025/AH1856/VB1159



# TRI-STATE TRAILER SALES, INC.

- Pittsburgh, PA (412) 747-7777
- Lancaster, PA (717) 569-4531
- Hubbard, OH (330) 534-0082
- Cincinnati, OH (513) 874-4880

## PARTS SPECIALS

**Ankra & Kinedyne**  
4"x30' Flat Hook Strap  
Part # KINE423021

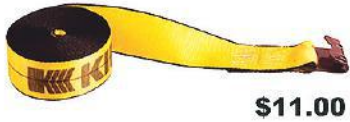

\$11.00

**RATCHET BINDER**  
Part # LDR-38-10



\$29.95



**Seal-Gap**  
(Roof Sealer)  
1 Gallon  
Part # SELA55

\$42.95



**3/8X20FT GR70 CHAIN**  
W/GRAB HOOKS  
Part # 54320

\$37.95

**5/16X20FT GR70**  
CHAIN W/GRAB HOOKS  
Part # 54317

\$32.95

**Steel Jack Bar**  
Part # KIN10085



\$19.95

**Chain Lever Binder**  
Part # 1010115

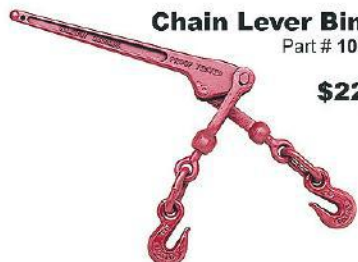

\$22.95

## NEW & USED TRAILERS

Qty 15 New Fontaine and Manac  
48'-80'x102" Extendable Flatbeds  
in Stock, Air and spring sliding  
tandem suspensions, Apitong floors,  
12 sliding winches



Qty 50 - 2004-2006 Wabash Electronics Vans  
53'x102"x13'6" air ride tandem, 17.5 Steel wheels / Tires,  
swing Doors, alum roof, hd Scuff and ceiling Liners



Qty 12 - New 2016  
Reitnour Dropdecks and Flatbeds



Qty 4 2009 -10 Utility Flatbeds 48'x102" Combo Spread  
Axles, alum flat bulkheads, winch track / winches



2014 East MMX 53'x102" Alum flatbed  
with Lightweight sidekit and sliding rear axle,  
coil pkg, 11R24.5 Alum wheels. Very clean unit.



**Universal** » PEOPLE DRIVEN SOLUTIONS

**WE MOVE FORWARD TOGETHER**

**DRIVE WITH A NATIONWIDE COMPANY WITH THE SUPPORT, RESPECT AND BENEFITS YOU DESERVE**

1,000's of job positions open throughout our growing company

**OWNER OPERATORS**

**COMPANY DRIVERS**

**DRIVER TRAINERS**

### BENEFITS

- » GENEROUS SIGN-ON BONUSES
- » WEEKLY SETTLEMENTS
- » 100% ALL FSC IN MANY LOCATIONS
- » COMPETITIVE PAY
- » MORE HOME TIME
- » FREE FULLY STOCKED LOAD BOARD
- » CHOOSE YOUR LOADS
- » U-SAV PROGRAM
- » RENTAL TRAILERS
- » RESPECTFUL COMPANY CULTURE

**JOIN UNIVERSAL TODAY | 877-883-1237 » DRIVEUNIVERSAL.COM**

## Howes Lubricator Contributes \$25,000 to Scholarships for Truckers



Once again Howes has partnered with SAGE Truck Driving Schools to offer the "Howes Truckers of Tomorrow Scholarship Program." One thousand dollar scholarships will be awarded to one student at each of the 25 SAGE schools, located nationwide, throughout the year. The program was a huge success last year and Howes Lubri-

cator is anticipating that 2016 will be just as successful. Applicants must meet all trucking industry qualifications and demonstrate a financial need in order to be eligible for application.

"We want to lend a hand to as many people as possible," says Rob Howes, president of Howes Lubricator. "So we are spreading out the

funds in order to help numerous students all year long. Each Howes scholarship is worth \$1,000 and that means helping 25 individual truck drivers by the end of the year." SAGE Truck Driving Schools provide high quality one-on-one CDL training of entry-level commercial truck drivers and driver training for some of America's Fortune 100 companies and fleets. Howes Lubricator provides drivers and their rigs with an unbeatable line of professional grade additives and also looks to enhance the industry by supporting expertly trained drivers on the road. Howes adds, "When your family has been a part of the trucking community for as long as ours has, you truly embrace the opportunity to give back and to do all you can to contribute to a strong industry future."

Details are available on the Howes website, the Howes Facebook Page, or by calling 1-800-GET-HOWES.

**Got Knee Pain? Back Pain? Shoulder Pain?** Get a pain-relieving brace -little or NO cost to you. Medicare Patients Call Health Hotline Now! 1-800-419-3684

**Life Alert. 24/7.** One press of a button sends help FAST! Medical, Fire, Burglar. Even if you can't reach a phone! FREE Brochure. CALL 1-800-746-0979

**METAL ROOFING-** A real roof for your house, garage, barn. Roof, ceiling, siding. Closeout deals. Low prices. Fast delivery. [slateroadsupply.com](http://slateroadsupply.com) 717 445-5222

# QUALITY COLLISION, INC.

Committed to Quality.....Guaranteed!



Featuring:

## Truck Painting & Body Repair

- State of the Art Facility
- P.P.G. Certified
- Alignments
- Full Frame Straightening
- Towing
- Custom Paint Jobs Available
- Free Estimates
- Friendly and Knowledgeable Staff
- All Work Guaranteed
- We Handle All Insurance Claims

## Quality Collision Truck and RV

365 Courtdale Ave, Courtdale, PA 18704

**570-714-5581**

[www.qualitycollisioninc.com](http://www.qualitycollisioninc.com)

**HAIRPORT 1**  
Family Hair Care Center  
Haircuts for the Professional Driver  
Hair Cuts • Beard Trims • Perms • Colors  
**OPEN 6 DAYS A WEEK**  
**MONDAY THRU SATURDAY**  
**NO APPOINTMENT NECESSARY!**  
**PETRO** Stopping Centers®  
1-80 EXIT 226  
GIRARD, OHIO  
(330) 544-0602



# You've Got to Get Meaner...

## than the Deposits Constantly Attacking Your Engine.

Internal diesel injector deposits are a serious problem for trucks all year long. Clean them up with our new, stronger detergent package. Nothing protects your engine and boosts your power like Howes Meaner Power Kleaner. Grab a bottle today!

**PLUS:**

- ✓ Increases Fuel Economy
- ✓ Lubricates Entire Fuel System
- ✓ Removes the Water that Promotes Microbial Growth



# Howes Lubricator

Professional Grade Performance Since 1920

1-800 GET HOWES (438-4693) • [www.howeslube.com](http://www.howeslube.com)





**FREE**

**Howes Deluxe Long-Sleeve T-Shirt**  
when you purchase 3 bottles of Meaner Power Kleaner.  
Visit [www.howeslube.com](http://www.howeslube.com) or call 1-800 GET HOWES  
Offer ends: 9/30/16, available while supplies last.



# 2016 WAUPUN TRUCK 'N SHOW

All Photos by High Gear Photography Complete truck show coverage at [www.movinout.com](http://www.movinout.com)



## Exceptional, high quality used trucks

- All types of used trucks, tractors and trailers
- Maintenance history available
- Online inventory updated daily

[gopenske.com/ad/mo](http://gopenske.com/ad/mo)

866-532-1885

# Miller Truck Lines – Providing World Class Transportation Services



Bonnie and James Miller

continued from page 1  
 comprised of about half company equipment and half independent contractors. Miller Truck Lines specializes in JIT (Just In Time) supply chain logistics in addition to truckload, dedicated and general hauling. They even operate their own regional wrecker fleet, including a full service shop and fueling services for their own fleet, as well as their contractor's convenience. A diverse offering of freight means steady work for Miller Truck Lines drivers. The refrigerated division concentrates on frozen goods and produce while the dry van division hauls manufactured products, beverages and beverage containers. Both divisions are,

for the most part, repetitive runs. On the flatbed side, Miller hauls steel, lumber and industrial air conditioners on irregular routes. There are also some stepdecks used for specialized hauling. Miller's tanker division hauls asphalt and oil with other bulk commodities in their pneumatic trailers. A testament to their diversity; Miller Truck Lines once hauled a load of sharks from Las Vegas, Nevada to the Tulsa, Oklahoma Aquarium. Flatbed equipment operates in all 48 states and Canada, while refrigerated units run primarily from Oklahoma to points on the East and West Coast. Tankers, pneumatics and roll-offs for the most part, do local work. The flatbed division can

hire and lease drives in all 48 states and refrigerated and dry van drivers within Miller's service area. Pneumatic, tanker and roll-off drivers should be located near the Stroud or Tulsa areas. The company keeps all of their drivers loaded both ways and running. It takes a total team effort to keep the wheels turning at Miller Truck Lines. First the recruiters make sure that the company is a good fit for the driver in regards to where they live and what kind of work they want to do. Then the dispatchers insure that drivers and contractors are kept loaded and moving, both outbound and inbound. The most important link in the chain is the drivers themselves. They

insure that freight is delivered on time and help foster good relationships with shippers so that Miller can provide superior service at a premium rate.

With their continued growth, Miller Truck Lines is able to offer opportunities for company drivers and independent contractors. The company has recently introduced a new pay plan in the refrigerated division that works off of a mileage based pay, plus incentives and bonuses. Miller also pays for all lumper services. The flatbed division has consistent freight on a percentage pay basis that also offers bonuses and incentives. Miller Truck Lines is 100% E:Log compliant, but the company provides all the log equipment and training to their drivers and contractors.

Independent Contractors receive 100% of the fuel surcharge and are welcome to take advantage of fuel discounts available at truckstops and travel plazas across the country. Miller also has negotiated discounted insurance plans for their contractors and will pay for plates and permits, providing the truck owner hauls the minimum required amount of loads.

The Miller family is very proud of their drivers and employees. Through their combined efforts, Miller Truck Lines is able to enjoy low CSA scores, while also creating a safer working environment for the drivers. The company continues to take a conservative approach to their operations, which enables steady, controlled growth, year after year. Because each

driver has a personal preference of which truck they like to drive, Miller Truck Lines' fleet is a mix of well maintained Freightliner, Peterbilt and Kenworth tractors. The company strives to give drivers a choice of which tractor they would like to drive. Newer equipment is assigned to regional and long haul work and older equipment is used for local hauls.

If you are interested in a career at Miller Truck Lines, they require 2 years of OTR experience, a good driving record and low CSA scores. Learn more by logging onto [www.millertrucklines.com](http://www.millertrucklines.com) or phone 918.447.2103. You can also apply online to Miller Truck Lines by logging onto [www.movinout.com](http://www.movinout.com) and accessing the Online Recruiting App.

## CAT READY KENWORTH GLIDERS

### W900 • T800 • T660



**Choice of CAT or Cummins Power**  
**Includes Nationwide Warranty**



### YOUNGSTOWN KENWORTH

**800-321-2056**  
[www.youngstownkenworth.com](http://www.youngstownkenworth.com)  
 7255 Hubbard-Masury Road, Hubbard, Ohio • I-80 Exit 234

# OWNER-OPERATORS

## Are you ready to make the best Career Decisions?

COMPANY DRIVERS  
ALSO WELCOME





# miller

## TRUCK LINES INC.

### REFRIGERATED DIVISION

Check Out our **NEW PAY PLAN!**

### FLATBED DIVISION

Consistent Customer Freight



**Miller Truck Lines** is currently seeking Owner-Operators for their Van, Reefer & Flatbed Divisions to run throughout 48 States and Canada.

# 918-447-2103

Apply Now at [www.millertrucklines.com](http://www.millertrucklines.com)

- Weekly Settlements (direct deposit)
- National Fuel Network discounts
- All lumper services paid
- Truck insurance discounts
- 100% Fuel surcharge passed on
- Free plates & permits

# DDEC Timing Shifts

There are tens of thousands of parameters in an ECM program but at the end of the day those calculations boil down to two basic things, injection timing and pulse width. In other words, how much fuel to fire and when to fire it? I've been tuning ECMs since around 2008 and for most of that time I knew a job was a success because the truck would put down more power to the road or a dynamometer. The basic idea was increasing engine output by increasing fuel quantity. At light and medium loads timing was almost always left alone because even with access to a dynamometer DDEC timing shifts were difficult to predict and control. It wasn't until I constructed the ECM lab and electronically controlled every variable that I realized the true nature of these timing shifts.

This all started by accident in March when I was running a 98 DDECIV 12.7 model TK for a customer. I took his DDEC IV to 1200

rpm and started charting out the injection timing and pulse width of his stock 500 program at 20 percent throttle. I worked my way up to 100 percent then I brought it back down to 20 percent. When I compared my numbers I thought I had done something wrong. The timing was completely different. After a while I realized that after being held at 1200 rpm for more than 26 seconds the timing would shift from 3 degrees BTDC to 24 degrees BTDC. No temperature or pressure changed, no change in throttle position, no change in rpm, only the fact that nothing changed for 26 seconds triggered the shift. I figured what I was seeing was either an old TK defeat device or an error in the programming. As it turns out TK programs have been mostly wiped out by dealer reflashes and what I was seeing was a defeat device. A program that was original from the factory from 1998. Since that first test I have

also found that memory errors in an ECM program can also cause a timing shift to happen randomly, mostly in a way that makes the truck run and smoke worse.

So why do timing shifts matter? Injection timing determines how much heat your engine absorbs and how much heat ends up in the exhaust. A shift in timing can be heard and can make your water temperature rise and your exhaust gas temperature drop. Proper injection timing makes the difference between an ECM program that gets good mileage and one that gets bad mileage. So if you believe your engine has good days and bad days and sometimes it just sounds different...you might not be crazy. It may be a problem with your ECM programming.

Written by Fernando DeMoura, Diesel Control Service LLC. Website: [www.dieselcontrolservice.com](http://www.dieselcontrolservice.com) Phone 412-327-9400



ECM Repairs - ECM Batteries - ECM Testing  
Caterpillar - Cummins - Detroit Diesel - MBE  
Over 1700 ECMs serviced



**\$999** for most dyno proven fuel mileage and horsepower ECM programs for Detroit Diesel, Cummins, and Cat

**Detroit Diesel Series 60: up to 650 hp 2500 rpm**

**Caterpillar 3406E - C15 - ACERT : up to 650 hp 2300 rpm**

**Cummins SIGNATURE/PRE EGR ISX: up to 625 hp 2300 rpm**

Looking for adjustable horsepower?  
See our Triple play Series 60 ECM programs in action at [dieselcontrolservice.com](http://dieselcontrolservice.com) or on our YouTube channel

DCS Series 60 DDEC TRIPLE PLAY ECM PROGRAMS  
You choose when to switch to your high fuel mileage program, your high horsepower program and when to switch back to your stock ECM program.

- 3 DDEC ECM programs in 1 (for DDEC III, IV and V engines)
- Change between 3 different dyno proven fuel, timing, engine response, and rpm limit settings on the fly.
- No sensors cheated
- The only install needed is a switch to the ECM
- Available only at DCS



**MATS booth #60072**

DCS Lab Address : Diesel Control Service  
615 Pillow Ave,  
Cheswick, Pa 15024

**412-327-9400**

[www.dieselcontrolservice.com](http://www.dieselcontrolservice.com)



**W.C. Sauers Trucking**

Cranberry Township, PA

**BE HOME ON THE WEEKENDS!**

RUN REGIONALLY IN • PA • NY • CT • MA • NH • OH • IN • KY

Sauers is a Small company where Drivers are valued for all they do. We have dedicated customers, all Dry Van Freight, No Touch, No Hazmat, Out Bound Pickup is 95% Drop and Hook. Drivers assigned Late-Model Tractors. Our Service Garage sees and checks your equipment every weekend and keeps it in excellent condition.

Mileage pay based on experience and MVR. Benefit package includes Health (Currently Highmark), Dental, Eye Care and Life Insurance, 401K plan with employer match, paid vacations, safety and fuel bonuses.



**724.776.2167 x228 • 800.245.1944 x224**  
[www.wcsauers.com](http://www.wcsauers.com)

**HIGHEST PAID IN THE INDUSTRY**



**Skelton TRUCK LINES** SINCE 1962

**STOP BEING JUST A TRUCK NUMBER**  
make more money and a better quality of life.

**NOW HIRING** TEAM OWNER-OPERATORS & TEAM COMPANY DRIVERS  
IMMEDIATE OPENINGS IN: *Indiana, Pennsylvania, California and Georgia*

**We Require:**

- 3 years driving Experience
- Hazmat Endorsement, passport, or enhanced CDL an asset
- Good MVR
- Clean Criminal Record

**We Pay:**

- Fuel Surcharges
- Safety Incentives 3cpm
- Pickups/Deliveries
- Saturday/Sunday Departures
- Medical

- Company Paid Insurance
- US/Canada Border Crossings
- Layover/Waiting Time
- 401K Contributions
- Paid Orientation

**OWNER-OPERATOR TEAMS AVERAGE \$1.80/HUB MILE**  
**COMPANY TEAMS AVERAGE \$0.76/HUB MILE**

Call or e-mail  
Lesia Shyshko  
**800.387.9796**  
[lesia@skeltontruck.com](mailto:lesia@skeltontruck.com)  
Call or Fax  
Senior VP Ron Skelton  
**647.828.1178**  
or fax your information to  
905.895.1314

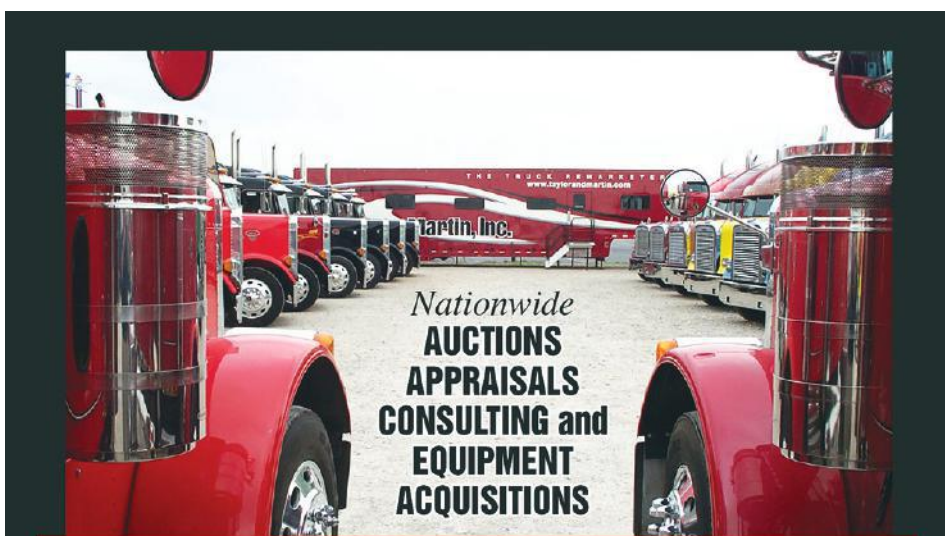

Nationwide  
AUCTIONS  
APPRAISALS  
CONSULTING and  
EQUIPMENT  
ACQUISITIONS

**UPCOMING AUCTION NOTIFICATION!**  
**PITTSBURGH, PENNSYLVANIA**  
**THURSDAY, MAY 19, 2016**

If You Want Your Equipment Advertised In Our Pennsylvania Brochure, Please Call By Monday, April 18!

**800-654-8280**



**Taylor & Martin, Inc.**  
AUCTIONEERS  
www.taylorandmartin.com



**RICHIE GUIFFREDO**  
Sales Representative  
(E)PA, NY, New England States  
Mobile: (570) 575-6139  
Fax: (570) 503-1772  
rguiffredo@taylorandmartin.com

**JIM AUGUST**  
Sales Representative  
OH, WV, (W)PA  
Mobile: (724) 462-1445  
Fax: (402) 727-6183  
jaugust@taylorandmartin.com



**Taylor & Martin, Inc.**  
AUCTIONEERS  
www.taylorandmartin.com

**800-654-8280**

VISIT OUR WEBSITE TO VIEW OUR COMPLETE UPCOMING AUCTION SCHEDULE!

**GLIDERS AND USED TRUCKS IN STOCK**



**2016 Freightliner Coronado Glider kits**  
• 70" Midroofs and Condos • 500 Detroit  
• 13 Speed Trans • Variety of colors  
**Western Star Gliders also available**



**Used 2012 Kenworth T660**  
70" Double Bunk, ISX Cummins 475hp.  
10spd. Air Ride Aluminum wheels  
Several Good Used Trucks in Stock

**Gliders 3 year Nationwide Power Train Warranty**  
**3.99% Financing Available for Qualified Buyers.**

**GENEVA Truck and Equipment Inc.**

**I-79 EXIT 144 COCHRANTON PA. 814-337-7136**  
Go To Our Website [WWW.GENEVATRUCK.COM](http://WWW.GENEVATRUCK.COM) For Complete Inventory

**AWL TRANSPORT dba TLX WANTS YOU!!!**

**OWNER OPERATORS - FLEET OWNERS & COMPANY DRIVERS FOR THEIR** **TLX**  
**FLATBED DIVISION**

AWL Transport, Inc.

**OWNER OPERATORS**

- Home Weekends
- 75% of 100%
- 100% Fuel Surcharge
- Weekly Pay
- Direct Deposit
- Insurance Available for Physical Damage, Bobtail/Deadhead
- Lease Purchase Program
- Rider Program

**\$1000 SIGN ON BONUS**



**COMPANY DRIVERS**

- Home Weekends
- Excellent Pay & Benefits
- Orientation Pay
- Guarantee Pay
- Weekly Pay
- Direct Deposit
- Life, Health, Dental & Vision
- Paid Holidays & Vacations
- Rider Program

• Plus Much More •

**Drive for a Family Run Company where Safety & Service = Success**  
**Call Today or apply online [www.tlxtransport.com](http://www.tlxtransport.com)**

**Northern Region Jim - 330-594-5372**  
**Southern Region Bill - 270-683-3131**

**AG-HAULIN**  
**FLO**  
**PROTECTING THE RIG THAT RUNS YOUR BUSINESS!**

**HIT THE ROAD WITH:**

- FLEXIBLE PAYMENT PLANS
- DOWNTIME REIMBURSEMENT
- ONLINE CERTIFICATES

**COLLECT THEM ALL!**

**1-800-PROGRESSIVE**  
**PROGRESSIVE.COM**

**PROGRESSIVE COMMERCIAL**

Progressive Casualty Ins. Co. & affiliates. All coverage subject to policy terms.

# BERM NOTES



by Henry Albert

Every business owner knows that to be successful you have to find your niche and those special qualities in yourself and your business that will make you stand out from your competition.

Customers don't always shop on price alone. They want value and it's up to you to create ways in which to increase your value in the market. For example, you can offer something that your competition doesn't. Observe or call your competition to hear how they do things and figure out ways to elevate your game.

Many businesses today are not even doing the basics in regards to offering good customer service. Have you had poor service recently at an establishment? How does it make you feel? Wouldn't it be much better to be treated like a VIP. It's one thing to get a loaf of crispy French bread at your local bakery that tastes like a million dollars. It's another thing to have it served to you by a person who obviously hates their job.

Many times in my business during the loading process or delivery to our customers, I would take a box of fresh doughnuts to the shipping department. They always enjoyed having that small treat in the morning. Doing this also invited good positive conversation with those who enjoyed the doughnuts. If it was a very hot day, I would bring some iced tea and sodas. The workers loading/unloading on the hot pavement with the sun beating down on them in very hot/humid temperatures sure enjoyed those cold drinks in the afternoon. These people never forgot me and were always appreciative. It's not that you have to do a lot for people but sometimes a small personal thing can go really far. For me, this was a way to personalize my service to our customers.

Find ways to add more value or improve your service. Anything you can do to assist your shipper in making their job easier goes a long way. Always smile, be friendly and have a good attitude. If an issue should arise, handle it with professionalism and seek the best solution. Your personal appearance is very important and should always be neat, clean and professional. To set your business apart, you could create a uniform for yourself to include company colors and your business logo.

For me, I have broken the rules so to speak...what flatbed driver do you know wears a button down uniform shirt with a tie every day to work? Don't be afraid to be different. Yes, it might mean taking a risk and going it alone. I have had my fellow drivers laugh in my face and make negative remarks about my professional appearance. Sometimes it's good to be talked about and stand out from the crowd. You can't set yourself apart if you're always following what everyone else is doing. Take a chance...

Once you have secured and are working for your customers, make sure to follow up with them. I am



TICKET DEFENSE TICKET DEFENSE

**Got a Ticket? Fight it!**  
Protect Your CDL  
**COAST TO COAST  
LEGAL SERVICES**

✓ Reasonable Rates **All Tickets Handled by**  
✓ No Monthly Dues **Licensed Attorneys**

**1-888-266-0499**  
www.coasttocoastticketreferral.com

surprised how many people don't follow up or check in to see how service is performing. Customers may neglect to bring up small things but when you ask if you can make any improvements, they will be more willing to share their issues with you.

Trucking is a people business so establishing and maintaining those long term business relationships will put you on the road to success. I hope this helps in establishing some ways to set your business apart from the competition.

**PA COMMERCIAL REGISTRATION**  
START NEW COMMERCIAL ACCOUNTS  
RENEW EXISTING APPORTIONED PLATES

**We can HELP set up NEW Commercial Accounts with PennDOT!**  
Help with Mileage, 2290, DOT #, ICC, MC

193 City Ave.  
(Montgomery and Philadelphia County)

Purchasing New Trucks?  
We can do ALL yor TITLE work!

PA Title Transfers  
CDL Replacements and Renewals  
Drivers License Restorations

**The Imperial Agency, Inc.**  
state & service fees apply

(610) 617-8850 ask for KIM  
www.imperialautotags.com

**2016 WHEEL JAM TRUCK SHOW**  
JUNE 3 - 5, 2016  
South Dakota State Fairgrounds, Huron, SD

WheelJamTruckShow.com  
#WJTRUCKSHOW

SCOTT MARONE  
605.385.0239

MTI-TRUCK DRIVING SIMULATOR  
LIGHT SHOW JUDGED TRUCK SHOW SHOW'N SHINE  
DYNAMIC ENGINE BRAKE COMPETITION

ROADWORKS  
LINCOLN CHROME  
GREAT PLAINS TRUCK PARTS  
VE  
HATCO AUTO

Produced by  
**18 WHEEL**

**Triple K Fleet Services** INCORPORATED  
Keeping your fleet on the road.

**717-635-7500**

**24 HR. TOWING AND ROAD SERVICE!**

www.triplekfleet.com

**FULL SERVICE MULTI-BAY SHOPS  
MEDIUM & HEAVY WRECKERS  
HEAVY HAUL TRANSPORT**

**LOCATED IN CARLISLE & HARRISBURG PA**

EXIT 44 OFF I-81  
1220 NEWVILLE ROAD  
CARLISLE, PA 17013

EXIT 77 OFF I-81  
7800 LINGLESTOWN ROAD  
HARRISBURG, PA 17112

**SHOW THIS COUPON AND GET A FREE T-SHIRT**  
Limited One Per Customer.  
Exp. 3/31/16

facebook

**AXLE SURGEONS** Of Central PA

**717-395-5730**

**WE NOW DO SPIDER PLATES!!**

**1/4 THE COST OF A NEW HOUSING AND LESS DOWN TIME!**

**\$100 OFF your next spindle job**  
with this ad or coupon

**AXLE SURGEONS** Of Central PA  
Exp. 3/31/16

The mobile Spindle Replacement Specialists...

# Kirk Trucking Service Embodies Safety With Eyes On Fleet Expansion

Through nearly seventy-five years of business, Kirk Trucking Service has been supporting industry in the greater Pittsburgh area and nationwide with expert drivers and a sharp focus on safety and quality service. One way the company motivates its drivers is through its Driver of the Month program. The driver who earns this accolade is accident and incident free, known for punctuality and often praised by customers and brokers. He or she is presented with a monetary bonus, a certificate and added to a plaque maintained in the drivers lounge at the corporate office.

However, from March 30<sup>th</sup> to June 1<sup>st</sup> of this year, any Kirk driver

who stands a DOT inspection with zero violations or infractions will be awarded a one hundred dollar bonus and a company jacket designed for spring weather in Pennsylvania.

November's Driver of the Month was Larry. He is an owner operator who has been with the company for over eighteen years. Larry has recently purchased a new Benson flatbed trailer from Reno's Trailer Sales.

Mr. December was Doug, another owner operator who's tenure with Kirk Trucking spans over ten years. Doug has recently purchased a new Freightliner tractor along with a new East flatbed trailer. In efforts



Larry, Kirk Trucking's November Driver of the Month.

to expand, the company is actively recruiting owner operators with various hauling experience to join their fleet.



Doug, Kirk Trucking's December Driver of the Month, is a Marine combat veteran and Naval Achievement Medal recipient with extensive training through their service. Prior service members of the motor transport fields are highly encouraged to apply. Since his arrival, Kirk has joined forces with the Show Your Stripes program in efforts to strengthen their team with aggressive and motivated veterans who have received extensive training through their service. Prior service members of the motor transport fields are highly encouraged to apply.

**THEY ARE COUNTING ON YOU!**  
Snow! Wind! Rain! Ice! Heat! Extreme Cold!



SEE US AT  
**M.A.T.S.  
BOOTH  
#10096**

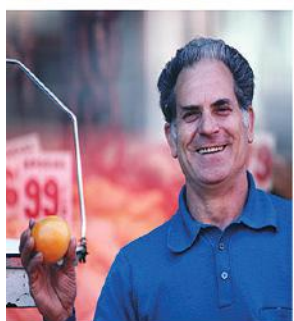

## FPPF Fuel Additives the right choice

Available throughout North America at Truckstops, Heavy Duty Parts Distributors, Repair Facilities, Truck Dealers and other outlets.

FPPF Chemical Co., Inc., Buffalo, NY  
1-800-735-3773 • www.fppf.com



**KIRK**  **70 YEARS OF SERVICE**

**Trucking Service Inc.**  
Pittsburgh, Pennsylvania  
"Service Is Our Only Product"

- Local • Regional • Long Haul
- Flats • Vans • Specialized Equipment

**Leasing  
Owner/Operators**

1-800-245-2452  
www.KirkTrucking.com

Seeking Agents in Detroit, Chicago and Cincinnati

**HUNTER**  
TRUCKS • PARTS • SERVICE  
SINCE 1938

- General Repairs for Truck and Trailer
- Now Cleaning DPF's • Open 24/7
- Factory Trained Technicians

Located at 3500 Parkway Drive Brookfield, Ohio  
In the Strimbu Trucking Facility at the Jcts of Rts 82 & 7

**Call (330) 448-6295**

**ALUMACLEAR**  
THE ULTIMATE ALUMINUM CLEAR COAT SYSTEM

The Alumaclear™ Aluminum Clear Coat System is an exclusive process that helps maintain a "fresh-from-the-factory" shine on a wide variety of aluminum equipment, including bumpers, wheels and trim.

Alumaclear™ is scientifically formulated to create a permanent bond with the aluminum surface it is applied to. And since there are no activators or hardeners used, Alumaclear remains flexible and expandable so it will not flake or peel off.

Visit Our Website at [www.alumaclear.com](http://www.alumaclear.com)  
Rob Loney - 231-510-7092

BRING YOUR EQUIPMENT TO ONE OF OUR LOCATIONS  
CALL US FOR A SHOP NEAR YOU!  
OR OUR MOBILE SERVICE WILL COME TO YOU ANYWHERE IN THE U.S.

See Us For All Your Custom Vinyl Wraps & Graphics

SEE US AT  
**M.A.T.S.  
BOOTH#  
76085**





# FLEET OWNERS: Want to grow your business? Join us.

Linehaul team opportunities at hub locations around the U.S.

## FedEx Ground offers:

### OUTSTANDING REVENUE POTENTIAL AND GROWTH OPPORTUNITIES

- Weekly settlement on all miles — loaded or empty
- Voluntary seasonal incentive programs
- Record package volume and expanding network

### FLEXIBLE BUSINESS OPERATIONS

- No-touch freight; 100 percent drop-and-hook
- Weekly home time for your business's employees

### ACCESS TO USEFUL RESOURCES

- Network of on-site fueling stations at wholesale price
- Third-party vendor programs and discounts — truck leasing, tires and more

For more information, call 1.866.832.6339 or go to [buildagroundbiz.com](http://buildagroundbiz.com).

FedEx Ground will contract only with businesses that are established under state law as corporations, are registered and in "good standing" with the state(s) in which they do business, and treat personnel who provide services under the agreement as employees.

# Boost MPG and Horse Power!

Removing air from the fuel gives you:

- ◆ Increased Fuel Economy
- ◆ Increased Power Output
- ◆ Improved Throttle Response
- ◆ Reduced Exhaust Emissions
- ◆ Extended Pump and Injector Life
- ◆ Quicker Starts
- ◆ Smoother Idle



[www.pureflowtechnologies.com](http://www.pureflowtechnologies.com)  
573-635-0555



## AirDog® II

Only **\$899**

**5 Year Warranty!!**

featuring the  
4G-HD Industrial  
Pump and  
Fuel Filter Monitor



MSRP \$1,195

Special Show Pricing

**BOOTH  
#17212**



## Champ I & II

**10 Year Warranty!!**

AirDog® Champ I



MSRP \$585  
Only **\$429**



AirDog® Champ II  
Installs in minutes

1. Remove fuel filter
2. Spin-on Champ II
3. Install Cat® fuel filter
4. Install Air/Vapor return line

# Industry News Briefs

## Courtesy of PMTA



For more information on PMTA (Pennsylvania Motor Truck Association), go to [www.pmta.org](http://www.pmta.org)

### Anti-coercion rule now in effect, protects drivers from brokers, carriers threatening 'economic harm'

CCJ reports, a new federal rule that implements large fines for carriers, shippers and brokers caught pressuring drivers to operate beyond federal safety regulations, such as when they're out of hours, is now in effect, as is a new system for truckers to file complaints for alleged coercion instances with the Federal Motor Carrier Safety Administration.

### Trailer Makers Finding Ways to Stretch 28-Footers

While politicians, Hill aides and lobbyists worked on or against legislation that would have allowed twin 33-foot trailers on the national highway system, manufacturers and their fleet customers took note, and the trailer makers busied themselves with improving techniques for stretching 28-foot pup trailers into 33-footers.

### Biden Calls for Increased Transportation Infrastructure Investment

The Commercial Appeal, Vice President Joe Biden called for greater public investment in transportation infrastructure during a Feb. 17 visit to a logistics yard east of Memphis, Tennessee. Dignitaries in suits and railroad workers in orange vests and hard hats listened as Biden spoke after touring the Memphis Regional Intermodal Facility south of Rossville, Tennessee. Biden said America can compete well with any nation in the world in attracting business because of favorable factors ranging from fair courts to productive workers. "But guess what?" he said. "If we do not improve our infrastructure — if we do not improve it — we will not take advantage of being able to lock down for the next 40 years that we remain the best place in the world to invest."

### Driver pay rises in first quarter

A new report shows that driver pay rose in the first quarter at a faster pace than at any time since trucking's last peak period almost 10 years ago. This is occurring as industry capacity shrinks and the driver shortage worsens. According to the report, the average increases are about 2 cents per mile for van drivers, with higher increases for refrigerated drivers and owner-operators.

The report says that is an increase of 5.8% in a single quarter, far faster than the average annual increase between 2009 and 2013. The last time that driver pay spiked was 2004 to 2006, when freight levels surged and turnover hit records.

### ATRI seeks for-hire motor carriers to share operational data

The American Transportation Research Institute launched a data collection initiative to update the 2013 Operation Costs of Trucking report. ATRI is using a brief online survey to capture basic cost information from for-hire carriers such as driver pay, fuel costs, insurance premiums and lease or purchase payments. Carriers are asked to provide full year 2013 costs per mile and costs per hour data.

The results of this data collection, combined with previous Op-

eration Costs of Trucking reports, will yield six full years of trucking cost information derived directly from fleet operations. This research provides carriers with an important high-level benchmarking tool and government agencies with real world data for future infrastructure improvement analyses.

For-hire motor carriers are encouraged to provide confidential operational cost data through ATRI's survey, available online at [www.atri-online.org](http://www.atri-online.org). The results of this study will be available later this year.

### Lower Oil Prices Push Down Cross-Border Freight

Large declines in the value of oil and other petroleum-related products during 2015 was reflected in a lower value of cross-border freight movements between the U.S. and its neighbors, according to new Transportation Department figures. The data shows the value of freight flows fell 7.2% in 2015 compared to a year earlier. That follows a 4.5% improvement in 2014 from 2013.

### ATRI Soliciting Trucking Industry Crash Cost Data For New Research

Arlington, VA - The American Transportation Research Institute (ATRI), the trucking industry's not-for-profit research organization, today launched a new data collection initiative to create a database of motor carrier crash costs by crash type and severity. This data collection will populate ATRI research designed to enable carriers to make better informed Onboard Safety System (OSS) deployment decisions.

This request for data is targeted toward motor carriers. ATRI is also working with its insurance industry partners to complete the crash cost database.

Participating motor carriers will be asked to provide information on common crash costs such as:

- Property Damage
- Attorney and Court Costs
- Towing and Recovery Costs

This research was identified as a top priority by ATRI's Research Advisory Committee and will update a number of Onboard Safety System cost-benefit analyses that ATRI has published over the past decade.

Motor carriers interested in supporting this research initiative can access the data request form on ATRI's website. All submitted data will be treated as confidential information and ATRI will provide a non-disclosure agreement if requested. The research will aggregate the data and no identifiable characteristics will be reported.

### DOT Estimates Value of Tonnage to Rise 84% by 2045

Transport Topics reports, according to a Department of Transportation study released March 3, the amount of freight moved by trucks in the United States will increase 44% by 2045 while its value will jump 84%. Trucks are by far the nation's most-used freight mode, moving 64% of tonnage and 69% of its value in Total freight moved on all modes, including trucks, is projected to reach 25 billion tons with its value expected to soar to \$37 billion.

### Typical U.S. Worker May Get Bigger Raises Than in the Jobs

### Report (\$)

According to The Wall Street Journal, the wage measure featured in Friday's jobs report may undershoot raises for the bulk of U.S. workers. The most closely watched wage figure, average hourly earnings for all employees, advanced 2.2% in February from a year earlier, the Labor Department said.

SOLO & TEAM COMPANY DRIVERS

# California

## OVERLAND, Ltd.

WABASHA, MN

WE ARE A FAMILY OWNED COMPANY WITH AN OPEN, FRIENDLY ATMOSPHERE. AT CALIFORNIA OVERLAND, DRIVERS ARE NOT JUST EMPLOYEES... THEY ARE FAMILY

We go the **extra mile** for our drivers

- COMPETITIVE PAY PACKAGE FOR COMPANY DRIVERS
- SIGN ON AND MONTHLY INCENTIVES
- WEEKLY SETTLEMENTS
- LATE MODEL EQUIPMENT
- SUPPLEMENTAL BENEFIT PACKAGE & 401K
- TRANS FLO
- MEDICAL BENEFITS
- CELL PHONE ALLOWANCE

CALL TODAY! (888)-700-2254, EXT. 124      APPLY ONLINE AT [CAOVERLAND.COM](http://CAOVERLAND.COM)

ALL OUR DRIVERS NOW ENJOY **FREE** SIRUSXM RADIO IN THEIR TRUCKS!

# DRIVERS NEEDED

Owner Operators  
Company OTR  
Lease Purchase

**NEW!** **PAY INCREASE**

WEEKLY HOME TIME • ALL STOPS PAID  
SAFETY BONUSES • HAZMAT PAY • FUEL DISCOUNTS

**JOIN US**

**CALL!**  
For more additional features offered to our FST Drivers

614.529.7900 EXT. 1540

AN EMPLOYEE OWNED COMPANY

**FST LOGISTICS**  
Since 1991

PAY INCREASE   WEEKLY HOME TIME   ALL STOPS PAID   SAFETY BONUSES   HAZMAT PAY   FUEL DISCOUNTS

CALL! FOR MORE ADDITIONAL FEATURES OFFERED TO OUR FST DRIVERS



# Understanding Trailer Alignment

By Steve Pollock



John Carlson, Service Manager at Girard Equipment.

GIRARD, OHIO... Have you ever seen someone going down the road pulling a trailer that is tracking to the side? There is a man who is leaving a trail of money behind him. While calculating loss of fuel mileage is probably difficult, you will definitely know how much money you've lost when you go to replace your trailer tires prematurely. A trailer axle out of alignment as little as 1/4 of an inch can cause the trailer to track to the side and make it nearly impossible to keep both tractor and trailer centered within your lane. Construction zones will really challenge your driving skills, maybe even upset a few people trying to pass you. What most drivers are not aware of is that if both axles are out of alignment, the trailer may track straight. While you might think everything is okay, the axles are working against each other, stealing horsepower from your tractor, while the tires are still scrubbing away. Unfortunately by the time you visibly see the trailer tires scrubbing, chances are the wear pattern has probably already gotten too severe. You will be buying new trailer tires before you have achieved a full service life from your present set.

Recently I had the opportunity to be educated about trailer alignment by John Carlson, Service Manager at Girard Equipment Company and Trailer Technician Steve Wayland. These trailer service professionals opened my eyes to some interesting facts and misconceptions about trailer alignment.

While all trailers come pre-aligned from the factory, over time the alignment can slip out of spec. Causes can be potholes, curbing the trailer or worn bushings. In extreme cases sometimes the axle or frame is bent, although about 90% of the time it is simply the trailer alignment.

Trailer axles have no easy toe or camber adjustment. The only ad-

justment is the "thrust angle," which is the direction the axles are headed compared to the frame of the unit. Each axle has its own adjustment and alignment is even more critical with multi-axle configurations.

In the old days a guy would take a tape measure, go underneath the trailer and measure the distance from the king pin to the wheel. Adjustments were then made until both sides were equal. The problem with this method is that any variance, such as a bow in the tape or simply not measuring to and from the same exact points will equate to a large waste of your time. When you add in the fact that the majority of fifth wheel pins are not exactly centered (some can be off by as much as 1/4"), a backyard alignment can become frustrating. Much like the simple plumbing job that turns into 3 hours and 4 trips to the hardware store, sometimes it's better to call someone who knows what they are doing. At least with plumbing you know if your job works if no water is leaking.

For the past 18 years Girard Equipment Company has been providing their customers with exacting Protrak QCT Lasar Alignment. All of the technicians are trained to perform trailer alignments. The method is simple but effective. A lasar alignment yoke is fastened to each wheel. A plumb bob is dropped from the trailer's side rail at the front of the trailer. A steel plate, marked in 1/8th inch graduations, is centered and aligned with the plumb bob. When the lasar is turned on, it will instantly show how much the axle is out of alignment. Newer trailers are quickly and easily adjusted with factory installed quick-align systems, older trailers will require more time. Each suspension requires a different adjustment method. With lasar alignment, however, the axle can be adjusted to a tolerance of 1/32 to

1/64 or basically about as good as it gets. Tandams and super singles are both adjusted in the same manner.

If you are checking your trailer for tracking while going down the road, remember that just about every road is built with a "crown" to facilitate water run off. This crown can cause some tracking and there is virtually no way to compensate for it. The only way to be absolutely sure about your trailer alignment is to have it checked. Checking the alignment will take about 45 minutes to an hour and costs a little over \$50.00. John Carlson recommends that you have your trailer checked for your own piece of mind, especially if the trailer has been in service for a while. Girard Equipment will provide an alignment form with a diagram that will show the alignment specs. They will advise you as to what needs to be done to align the trailer, how long it will take and how much it will cost to adjust. If you like, you can take your alignment profile, go home and adjust the trailer yourself. If so, just remember your last plumbing job. The trained technicians at Girard Equipment will also do a visual inspection of the trailer suspension and let you know if you have any problems.

Peace of mind when it comes to your trailer is not as expensive as you think. Call John Carlson at 800-686-2575 if you have questions about your trailer alignment. Always remember, even if you don't own the trailer, check the air pressure in the tires with a tire gauge before you hit the road. You might be surprised at how under inflated some trailer tires can be, and thumping will only find the ones that are severely under inflated. Even if the trailer belongs to someone else, the diesel fuel to pull it belongs to you, and air is still a lot cheaper than fuel.



1745 N State Street  
Girard, Ohio 44420  
800-686-2575  
www.GirardEquipmentCo.com

**Avoid Disaster!**  
Let us keep your trailer in line!



**\$54.99**

**Trailer Alignment Inspection**

\*Price does not include alignment or any repairs needed to align trailer



1745 N State Street  
Girard, Ohio 44420  
800-686-2575  
www.GirardEquipmentCo.com

## Southern Pride Trucking®

The Industry Leader in the Transportation of Jet Engines and Aircraft Parts

**WE'VE GOT THE RIGHT STUFF!**

**WE ARE EXPANDING OUR FLEET**



**800-4 PRIDE 1**

800-477-4331 | [www.sptnet.com](http://www.sptnet.com)

48 States - 100% OWNER-OPERATOR  
with a proven track record

**SINGLES**

Double Drop Trailer Wide Load Experience

**TEAMS**

Step Deck Trailer Established Team

## Truckers Solution – Real Solutions For Real Truckers

continued from page 1

Members won't need to get a new fuel card to take advantage of the Truckers Solution fuel discounts, as the discounts are available on EFS, TCHEK, FleetOne, FleetCore, MultiServe, TCH and Comdata cards.

Truckers Solution members save an average of \$0.16 off per gallon when they fuel. Fuel discounts are available at Loves, Pilot and Flying J; Ambassador Bridge and QuickFuel Fueling Centers. Other vendors offering discounts include: Good-year and American Motor Products (Michelin tires), Teladoc (medical), Match Factors (factoring), Porter Capital (factoring), Pegasus (document scanner), TSA (insurance discounts), Truckers Edge/DAT (load finding); Open Road Drivers Plan (legal assistance), and DBS Advantage (web design/social media marketing).

Here's what real-life, satisfied Truckers Solution customers have to say about the program:

Satisfied Member Dennis Ferron, Owner/Operator – Landstar said:

*"I never bought Michelin tires because I always thought they were too expensive. I saved over \$250 per tire! Do not buy tires without this discount and do not make the mistake I did and assume you cannot afford the best. Truckers Solution® has the best deal on the best tires!"*

Garry Walker, GL Walker, Inc. had this to say about Truckers Solution:

*"With Truckers Solution® we are able to operate at full speed and get instant savings on fuel. The customer support and the People that make up the organization are outstanding!"*

Truckers Solution has an office

in Orlando, Florida managed by Phillip Fulmer and another office in Franklin, Tennessee (south of Nashville) managed by Vickie Roberts. The Truckers Solution staff has a combined 100 years of experience in all areas of the trucking industry. The company's goals for the future are to grow the membership while

adding additional vendors, products, and services.

To learn more about Truckers Solution or to join, phone 352-241-6000 or visit them at [www.truckers-solution.com](http://www.truckers-solution.com) and they will email or fax you a membership form.

Truckers Solution – Advancing The Industry One Truck At A Time.

**Kenworth Northeast Group, Inc.**

<b>Buffalo</b> 716-852-2800	<b>Syracuse</b> 315-399-1400	<b>Elmira</b> 607-767-0057
<b>Rochester</b> 585-698-2940	<b>Albany</b> 518-213-3211	<b>Boston</b> 781-341-0008

**Don't Get Caught in the Cold!**

Kenworth Northeast Group, Inc. is offering special pricing on the Webasto Air Top 2000 ST with SmarTemp Control.

**\$950<sup>00</sup>**  
Plus Shipping  
Price good thru May 31<sup>st</sup>, 2016

P/N 5010609B

## We Are Looking for OTR Company Drivers!

Schuster Sells Safe Service First

# SCHUSTER



## JOIN THE SCHUSTER TEAM TODAY

- .40 to .43 Per Mile
- \$50 East Coast Pay
- \$40 per Billable Stop Charge
- \$40 Border Crossing Pay
- Direct Deposit
- 401K
- Excellent Health, Dental, and Eye Insurance
- Paid Orientation
- Great Weekly Miles
- Excellent Home Time; out 7-21 days (Depending where you live)
- Quarterly Safety Bonuses; Up to \$0.03 per Mile
- Assigned Trucks
- Pet Friendly
- Rider Program
- 24/7 Dispatch & Claim Services

*Schuster Company offers excellent pay, top-of-the-line equipment and terrific benefits. We are proud of our history and our reputation within the trucking industry and strive to hire the most professional and quality people available to drive for us. Schuster makes its driver selection with both safety and efficiency in mind.*

**QUALIFICATIONS:**

- Current Class A CDL license
- With 1 year Recent OTR Experience
- Be at least 21 years of age
- A stable and satisfactory work experience
- A good driving record
- Pass DOT medical, Drug & Physical requirements

Call today for immediate consideration

**1-800-831-4832**

**[www.schusterco.com](http://www.schusterco.com)**

# TRUCKERS SOLUTION MEMBERS

## Save an average \$0.16 PER GALLON!



**Visit us at M.A.T.S.  
IN BOOTH  
76241**

**TRUCKERS SOLUTION**  
REAL SOLUTIONS FOR REAL TRUCKERS

## USE ANY FUEL CARD

Comdata • EFS • MultiServ • Fleetone

## FUEL DISCOUNTS at

Love's • Pilot/Flying J • Ambassador Bridge

## Now Offering

## HUGE discounts on tires

Goodyear and Michelin

**CALL US FOR MORE INFORMATION 1-855-241-6001**

**or visit our website - [www.truckerssolution.com](http://www.truckerssolution.com)**



## GET YOUR FREE CATALOG!

- Go online to [www.iowa80.com](http://www.iowa80.com) and request your **FREE CATALOG** of the finest selection in Chrome and Professional Trucking Accessories!
- Or Call Toll Free – **866-4-IOWA80** (866-446-9280)
- Shop online today! [www.iowa80.com](http://www.iowa80.com)

# IOWA 80.COM

Truck Accessories For The Professional Driver MO 2016

## NOW HIRING DRIVERS IN:

**ATLANTA, GA., CHARLOTTE, NC. ROANOKE, VA  
PADUCAH, KY. COLUMBUS, MS. DALLAS, TX.**





**STARTING PAY .40 CPM  
AVERAGE MILES 2,800-3,000  
A WEEK  
FULL BENEFITS AFTER 60 DAYS**

**CALL 877-219-8345** **CRANE**  
[www.cranetransportinc.com](http://www.cranetransportinc.com) Transport Inc.

# THANK AVET

## Paul Rosta, E4 US Army Reserve

Paul Rosta served in the US Army Reserve from 2002-2005 and saw active duty from December 2003 to December 2004. Paul was attached to the 336 MP Battalion Division of the 89th MP Brigade from Ft. Hood, Texas. Paul was stationed at Camp Ashraf, Iraq. He was a member of (SRT) Special Response Team and (QRF) Quick Reactionary Force as well as driving an 88M Refueling Vehicle. During his tour in Iraq Paul spent most of his time with the 95 Bravos MPs, providing convoy security to prisoners and other government agencies (OGAs) as well logistics runs during which he was involved in 2 fire fights and 4 IED attacks. He would also occasionally help clear buildings. Paul credits MSG Gerald Day and MSG Jose Lopez with helping keep members of his unit alive. Paul has 6 children and lives in New Castle, Pennsylvania. He has been a cement mixer driver for Castle Builders Supply for the past 15 years.

**Our gratitude to Paul Rosta**  
and all veterans who have served our country.  
**"If you love your Freedom, Thank a Vet."**  
Send nominations and photos to [movinout@zoominternet.net](mailto:movinout@zoominternet.net)

## Tax Services, Accounting & Bookkeeping

- Seasonal/Annual Tax Returns & Services for Company Drivers, Owner Operators, Lease Operators, Independent Contractors & Fleet Owners
- Transportation Business Services
  - IFTA & HUT, Log Auditing & 2290 Filing
  - Incorporate for as low as \$150 (plus state filing fees)



**Haven**  
"Keeping you Rolling!"  
TRUCK & FLEET ACCOUNTING

**(715) 254-1333 • [www.haventruck.com](http://www.haventruck.com)**  
[contact@haventruck.com](mailto:contact@haventruck.com)

# LargeCarMag

Subscribe to the **PRINT** version of LargeCarMag!  
You will receive six issues per year. Just fill out this form and send it our way or sign up at [largecarmag.com](http://largecarmag.com)!

Domestic Subscription : \$50.00  
Canadian Subscription: \$60.00  
All Other Countries Subscription: \$65.00

Pay by Credit Card (Visa, MC, Discover):

Name on Card: \_\_\_\_\_  
Card #: \_\_\_\_\_  
Exp.: \_\_\_\_\_  
3 Digit Code (on back of card): \_\_\_\_\_  
Signature: \_\_\_\_\_

Name: \_\_\_\_\_  
Address: \_\_\_\_\_  
Address 2: \_\_\_\_\_  
City: \_\_\_\_\_  
State & Zip: \_\_\_\_\_  
Country: \_\_\_\_\_  
Phone #: \_\_\_\_\_  
Email: \_\_\_\_\_  
Company: \_\_\_\_\_

You can also mail a USD check/money order to:  
LargeCarMag  
PO Box 152  
New Providence, PA 17560

**How You Found Us:** \_\_\_\_\_

[www.LargeCarMag.com/subscribe](http://www.LargeCarMag.com/subscribe)

# TRAVEL ADVISORY

ON THE



## NORTHEASTERN EXTENSION LONG-TERM, SINGLE LANE TRAFFIC PATTERN

- March 14<sup>th</sup> – August 31<sup>st</sup>
- I-476 Milepost 101 – 105
- Both directions on the N.E. Ext.



Expect delays in this area at all times  
but especially during holidays and special events.  
We advise motorists who can, to avoid this area.

## Presidential Notes - Washington - "Pater Patriae"



by: Mike McGough

On January 6, 1759 Martha Dandridge Custis, a widow with two small children, married George Washington. They were married at the bride's home in Virginia. Mrs. Washington had two surviving young children from her first marriage. They were John Parke Custis and Martha Parke Custis, known affectionately as "Jacky"

and "Patsy."

As children, both Jacky and Patsy were loved and indulged by their mother and stepfather.

Sadly, they both died at a young age. In 1773, sixteen-year-old Patsy died during what was believed to be an epileptic seizure. Jacky, against Washington's advice, made a visit to the battlefield and camp following Washington's victory at Yorktown. On November 5, 1781, he died of "camp fever," a contagious illness that was prevalent throughout Revolutionary War camps.

Our first president demonstrated a father's love, commitment, and dedication to his country, and for that he is oft referred to as the *Father of His Country*. (The title *Pater Patriae*, a Latin phrase translated as "Father of the Country" or "Father of the Fatherland," dates back to the Roman Empire. For the Romans

it was a high honor bestowed on an individual by the Senate for outstanding service to the state.) There is no definitive evidence to document the exact origins of this esteemed reference to George Washington, but there were many. What is certain is that this respected sobriquet highlights the powerful leadership roles he played in the Revolutionary War, the Constitutional Convention, and during his two terms as president.

President Washington, remembered as the Father of His Country, fathered no children of his own. Nonetheless, he was a compassionate and devoted stepfather, grandfather and surrogate father to several nieces and nephews, making him the much loved and respected father figure of his family. It is indeed fortunate for the children of his family, that they were given the same fatherly love, commitment and dedication that distinguished Washington among our founding father and won for him the enduring acclaim of generations of Americans.

**Emergencies can strike at any time.** Wise Food Storage makes it easy to prepare with tasty, easy-to-cook meals that have a 25-year shelf life. FREE sample. Call: 800-970-5771

**ABANDONED FARMHOUSE!** 5 acres - Trout Stream - \$69,900. Handyman 3 BR house, stream, fields, views, beautiful Catskill Mountain setting! Call 888-431-7214 [NewYorkLandandLakes.com](http://NewYorkLandandLakes.com)

**GET OUR 2016 FREE CATALOG**  
WOULD YOU LIKE TO GET SPECIALS & NEW PRODUCT UPDATES? THEN GET ON OUR EMAIL  
**CALL 603-224-7370 OR GO TO WWW.BERUBES.COM**  
WE HAVE A MILLION DOLLAR INVENTORY AND A VERY KNOWLEDGEABLE STAFF. THAT MEANS YOU GET THE RIGHT STUFF RIGHT AWAY.

### More Than a Fuel Saver

- Decreased Drag
- Increase Fuel Mileage
- Increased Vehicle Stability
- Reduces Rear Spray

**1-866-758-4100**  
[www.airtab.com](http://www.airtab.com)  
See us at M.A.T.S. Booth # 68232 West Wing

**If you take loads from brokers there is something you should know...**

**If you want to get rid of Broker Loads, Load Training is the Answer!**

**FREE DVD**  
Visit [www.loadtraining.com](http://www.loadtraining.com)  
**1-800-776-7076**

## Build Your Trucking Business on a Strong Foundation.

For nearly forty years, Owner Operators have trusted Mercer Transportation for the freight and support needed to be successful.

Contact us today to discuss your goals and how Mercer can assist in helping you achieve them.

**We're Mercer Transportation. Rock Solid. Owner Operator Driven.**



1-888-703-2293

[www.mercertown.com](http://www.mercertown.com)

### BICEHOUSE CONSULTING & SERVICES

Your D.O.T. Compliance & Fuel Tax Service

- Authority
- Intrastate Authorities
- Log Auditing
- Boc-3 Filing



- IFTA Registration
- Qtrly Fuel Tax Filings
- Unified Carrier Reg.
- much more!

**Get Your Own Authority For \$500.00**

Price Includes: U.S. DOT #, MC # (OP-1), BOC-3 FMCSA Fees & BOC-3 Fees Included. Additional State Registration Fees not included

Quarterly Fuel Tax Reports Prepared for \$22.00 per unit/per month (Includes: IFTA, KYU, NM WDT, NY HUT Reports etc)

Call 1-(724)-333-3125

For a Free Quote today!

\* Over 15 yrs of Experience!

Bicehouse Consulting & Services | 1887 Sandy Lake-G.C. Rd. | Jackson Center, PA 16133  
[www.bicehouseconsulting.com](http://www.bicehouseconsulting.com) Email: [bicehouseconsulting@yahoo.com](mailto:bicehouseconsulting@yahoo.com)

#### NEW PRODUCT

#### NEW PRODUCT

**ELIMINATE DPF REGEN PROBLEMS!**

**ENERBURN®**

SEE US AT M.A.T.S. BOOTH # 70090



[www.betterdiesel.com](http://www.betterdiesel.com)

- **Keep your truck out of the service bay and start saving money today!**



**JKG**  
fuel solutions

612.209.3079

[jgates@betterdiesel.com](mailto:jgates@betterdiesel.com)

# Tax Talk: Tick Tock – The Tax Prep Clock



return is late.

The second is a failure-to-pay penalty (for paying late). The failure-to-pay penalty is generally one-half percent (0.005) per month of your unpaid taxes that are due. It applies for each month or part of a month your taxes remain unpaid, and starts accruing the day after taxes are due.

I suggest if you are worried that you cannot afford to pay in full, DO NOT let that prevent you from filing your return. Avoid that penalty all together!

What if you still just can't file by the deadline? Can you file an extension to avoid the late filing penalty?

Yes, but with restrictions. The bottom line is to avoid that penalty at all costs. You can always establish a resolution agreement with the IRS on any balance owed, so why not keep that balance from growing at a rate of 5% every month?

As always, if you need help, we're here to help file extensions, prepare your tax returns, resolve any tax debt, and look to see if you have any settlement options available. We can easily identify if your situation would fall into this category. Call us today at 1-844-346-3386 or visit [www.CommunityTax.com](http://www.CommunityTax.com) for more information.

**About the Author: Nick Charveron, is a licensed tax practitioner & Co-Founder of Big Rig Tax Relief LLC, a Tax Company focused on Tax Debt Resolution Services. Nick was a motor transport operator (88M) while enlisted in the Illinois National Guard, US Army. Email Nick at [Nick@BigRigTaxRelief.com](mailto:Nick@BigRigTaxRelief.com)**

While most everyone should have filed their taxes by now or are getting ready to finish filing Big Rig Tax Relief is here to help any truckers with last minute tax preparation or any back tax problem. Most of the country has until April 18 to file their taxes except Maine and Massachusetts who have until April 19. Obviously, we know the clock is ticking and the Internal Revenue service doesn't care why you have not or will not make the tax deadline. So what happens if you miss it?

First, understand this important rule: if you are due a refund there is no penalty if you file a late return, but if you are going to owe the IRS money then you have to file by deadline to avoid the penalties. So what are these penalties, and how bad is it?

According to the IRS, two penalties may apply. The first is a failure-to-file penalty for late filing (missing the deadline). The failure-to-file penalty is normally five percent (.05) of the unpaid taxes for each month that a tax

# Time to Join Make-A-Wish Mother's Day Truck Convoy

One of the happiest traffic jams of the year takes place every Mother's Day in Lancaster, Pa.

For 26 years, hundreds of trucks have gathered in a convoy to raise money for Make-A-Wish Philadelphia, Northern Delaware & Susquehanna Valley, a charity that grants wishes to children with life-threatening medical conditions.

The event began with one little boy's wish to ride in a truck and talk to his sister on CB radio and, thanks to the generosity of truckers, has grown into an all-day family celebration that raises hundreds of thousands of dollars. Last year, nearly 400 trucks from all over the country, many of them carrying Make-A-Wish kids, rolled through

central Pennsylvania as spectators lined roads and overpasses to cheer.

The Netherlands now holds the Guinness Book of World Records title for "World's Longest Truck Convoy," but we hope to win it back this year by drawing 500 trucks. The Mother's Day Convoy will be from 8:30 a.m. to 5 p.m.

Sunday, May 8 at Burle Industries, 1000 New Holland Avenue (Rt.23) Lancaster. To learn more and find out how you can participate, visit [www.http://philasv.wish.org/ways-to-help/convoy](http://philasv.wish.org/ways-to-help/convoy).

The presenting sponsor for the event is the RoadPro® Family of Brands.

## BUILT BY AMERICAN CRAFTSMEN

- ONE TRAILER AT A TIME -

TRAILSTAR INTERNATIONAL INC.

PHONE 330.821.9900 FAX 330.821.6941

20700 HARRISBURG-WESTVILLE RD. ALLIANCE, OHIO 44601

WWW.TRAILSTARINTL.COM • TRAILSTAR INTERNATIONAL INC

MADE IN THE USA

# Community Tax Can Help You With IRS Tax Problems

Community Tax has a proven track record of success assisting individuals and businesses nationwide with their IRS and State tax problems including:

- TAX DEBT RESOLUTION
- WAGE GARNISHMENT
- LIENS AND LEVIES
- TAX IDENTITY THEFT
- AND MORE

Our full-service tax services also include **ENTITY FORMATION AND PAYROLL SERVICES** at affordable costs.

Get more information from our website at [www.communitytax.com](http://www.communitytax.com), or call today to speak to a tax expert.



## Call Us Today! 1-844-346-3386

[www.communitytax.com](http://www.communitytax.com)



**Rated #1 Tax Company BY CONSUMERS ON CONSUMERAFFAIRS.COM**



ACCREDITED BUSINESS



SEE US AT  
M.A.T.S.  
BOOTH #  
74241



We travel to Truck Shows across the country, come say hello at our Big Rig Tax Relief Tent!



# MOVIN' OUT Calendar of Events

Sponsored by **speedco**

**TRUCK LUBE & TIRES**

**March 31 – April 2 – Mid-America Trucking Show** – Kentucky Exposition Center, Louisville, KY. For more info, <http://www.truckingshow.com/>

**April 15-16 – Marmon Truck Gathering** – Days Inn, 2104 N Central Express Way (Hwy. 75), McKinney, Texas. For more info email Ken Matuszak: [kcmarmon@earthlink.net](mailto:kcmarmon@earthlink.net)

**April 16 – 13th Annual Wheat State Antique Truck Show** – Newell's Truck Stop, I-35/US 50, Newton, KS. From 9-3. Trucks, cars, tractors, military, fire, 4 WD, original, restored, modified, whatever. Free entry/admission. Call Scott at 316-288-3443 or email: [dmarkshifflett@gmail.com](mailto:dmarkshifflett@gmail.com) or [www.athskansas.org](http://www.athskansas.org)

**April 22-24 – 18th Annual 75 Chrome Shop Truck Show** – 75 Chrome Shop, Exit 329 on I-75; 419 E State Road 44 Wildwood, FL 34785. For more info call 866-255-6206 or visit them on the web at [www.75chromeshop.com](http://www.75chromeshop.com)

**April 22-24 – Gulf Coast Big Rig Truck Show** – Houston, TX. For more info log onto [www.gulfcoastbigrigtruckshow.com](http://www.gulfcoastbigrigtruckshow.com)

**June 3-5 – Wheel Jam Truck Show** – South Dakota State Fairgrounds, Huron, SD. For more info go to [www.wheeljamtruckshow.com](http://www.wheeljamtruckshow.com)

**June 9-11 – 34th Annual Shell Rotella SuperRigs® Competition Truck Show** – Joplin Convention and Trade Center, Joplin, MO. The Shell Rotella SuperRigs® competition is the premier truck beauty contest for actively working trucks. Owner/operator truckers from across the United States and Canada compete each year for cash and prizes. Additionally, 12 lucky drivers will be selected to have their trucks featured in the Shell Rotella SuperRigs® calendar. Trucks are judged by industry professionals who score the rigs on exterior appearance, design, detail/finish, originality, and workmanship. In total, 18 working trucks receive awards for categories such as Best of Show, Tractor, Tractor/Trailer Combination and Classic categories.

**June 10-11 – Western PA Pride and Shine Truck Show and Drag Race** – Stoneboro Fairgrounds, Stoneboro, PA. For information contact Jason at 724-944-6468. For more info visit [www.paprideandshine.com](http://www.paprideandshine.com)

**June 17-18 – 37th Annual ATCA National Meet and Flea Market** – Macungie Memorial Park, 50 N. Poplar St., Macungie, PA 18062. Over 600 Antique Trucks, Participation Plaques, Food Vendors, Truck Corral, Flea Market and Crafters, Shaded Playground Area. For more info visit: [www.anti-quetruckclub.org](http://www.anti-quetruckclub.org) or [www.anti-quetruckclubofamerica.org](http://www.anti-quetruckclubofamerica.org)

**June 18 – Down Home Truck Show** – Humboldt, Nebraska. Truck Show for working trucks, antique farm tractors. Vendors, Kiddie Pedal Pull, Food. Free admission. For more info call Susie at 402-414-7021 or email [jimshupp@hotmail.com](mailto:jimshupp@hotmail.com)

**June 18-19 – 5th Annual Ohio Vintage Truck Jamboree** – Ashland County Fairgrounds, 2042 Claremont Ave., Ashland, OH 44805. Hosted by the Ohio Chapters of the American Truck Historical Society. 9 am to 5 pm both days. Vintage Truck Show, Trucking Memorabilia Display, Swap Meet, Light Show, Jake-Off, Slow Race, Hook & Drop, Country Convoy and Truck Pull. In lieu of registration and admission fees – donations to Ashland Food Bank and Shriner's Transportation Fund are appreciated. Contact Bill Peters at 330-682-1717 or email: [wep55@gmail.com](mailto:wep55@gmail.com)

**July 14-16 – 37th Annual Walcott Truckers Jamboree** – Iowa 80 Truckstop, I-80 Exit 284, Walcott, IA. Super Beauty Truck Show, Antique Truck Display, Trucker Olympics Games, Exhibits, Fireworks, Live Music and much more!! For more information go to <http://iowa80truckstop.com/trucker-jamboree/>

**July 15-16 – Expedite Expo** – Lexington Center, Lexington, KY. The only trade event focusing exclusively on the expedited trucking industry will be at the Lexington Center for 2016 on July 15 & 16. People from all over North America will come to learn about the newest trucks, career opportunities and products geared specifically to owner operators and drivers. For more info phone 859-746-2046 or go to [www.expediteexpo.com](http://www.expediteexpo.com)

**July 17- Uncle Sam Chapter Antique Truck Show** – Washington County Fair, Rt. 29, Greenwich, NY. Rain or Shine. No Registration Fee, \$2.00 Entry Fee. Vendors Welcome. For more information contact Clarence Ritchie at 518-642-9437 or Andy Hill at 518-753-2169.

**August 6 – 12th Annual Iowa-Nebraska Classic Truck Show plus the Nebraska Trucking Association Working Truck Show** – Sapp Bros. Truck Show – I-80 Exit 440, Omaha, Nebraska (Northwest Parking Lot). Food, Fun, Vendors, Trucking Memorabilia and Music. Contact Rusell Spawn, Jr. at 402-680-6121.

**August 12-13 - The 27th Annual Waupun Truck N Show** - Truck-n-Show festival grounds (Spring Street in Waupun), Waupun, WI. For more info visit [www.waupuntrucknshow.com](http://www.waupuntrucknshow.com). Phone: 920-324-9985 · Fax: 920-324-0353

**August 13 - 2016 Cerni Motor Sales and Penn Ohio ATCA Truck, Car and Motorcycle Show** – 5751 Cerni Place, Youngstown, Ohio 44515. 8 am to 4 pm. Everyone is welcome to attend/participate. Monetary and/or non-perishable food item donations for the Second Harvest Food Bank of the Mahoning Valley, a member of Feeding America, will be accepted in lieu of registration and admission fees. For more info contact Martin Palich at 330-978-8216 or email [PennOhioATCA@gmail.com](mailto:PennOhioATCA@gmail.com)

**August 19-21 – National Toy Truck 'N Construction Show** - Indianapolis Marriott East, 7202 East 21st St., Indianapolis, IN. For more info call 800-533-8293 or visit [www.toytrucker.com](http://www.toytrucker.com)

**September 17 – 40th Annual US Diesel Truckin' Nationals & Motorsports Spectacular** – Raceway Park, 230 Pension Rd., Englishtown, NJ. For more info visit [www.usdieselnationals.com](http://www.usdieselnationals.com) or [www.racewaypark.com](http://www.racewaypark.com)

**September 17-18 – Smicksburg Antique Tractor and Truck Show** – Dayton Fairgrounds, Dayton, PA. For more info call Kevin Bash at 814-257-9880 or Kevin McIntire at 724-525-4855.

**September 23-24- Guilty By Association Truck Show (GBATS)** – 4 State Trucks/Chrome Shop Mafia, Joplin, MO. Family Friendly fun-filled weekend with the crew! Make sure to participate in this year's 1st annual SWAP MEET for truckers to buy, sell & trade big rig parts for great deals! Weekend is jam-packed with storewide discounts, big rig burn outs, shop tours, a LUCAS OIL truck & tractor pull and a record holding 400+ truck convoy benefiting Special Olympics, followed by a Street Party & Concert in downtown Joplin! No Entry Fee-Everyone Welcome! Call 888-875-7787 Ext 161 or email: [gbatsinfo@4statetrucks.com](mailto:gbatsinfo@4statetrucks.com)

**October 21-23 – American Truck Fest** – Westworld of Scottsdale, 16601 North Pima Road, Scottsdale, AZ 85260. Trucking Expo, Truck Show, Awards Gala, Truck Auction, Industry Job Fair. For more info contact The Knight Agency at 480-447-9996 or visit [www.americantruckfest.com](http://www.americantruckfest.com)

If you would like to list an upcoming show or event, send all the details including a telephone contact number to

Movin' Out, P.O. Box 97, Slippery Rock, PA 16057 or fax us at 724-794-1314,

email: [movinout@zoominternet.net](mailto:movinout@zoominternet.net).

Visit us on the web at [www.movinout.com](http://www.movinout.com)

## Trucker Steve - "Your Road Map To Health"

My name is Steve, Trucker Steve, and I have battled high blood pressure and white-coat syndrome for as long as I can remember. I am now 60 years old.

I have spent 35 years behind the windshield and know only too well the stress that a trucker endures daily and how it affects our health.

The down time I had was spent researching medical issues in Pubmed, medical books, magazines looking for answers to resolve my personal medical issues probably the same ones you have.

Hopefully by sharing my research, experiences and hard learned lessons with you I can keep my trucking family on the road and help you take control of your health.

Here are a few things I have learned to do for myself to lower my blood pressure for the DOT physical.

1. Breathe deep for 15 minutes before testing. Shallow breathing increases blood pressure. Deep respiration requires more exhale than the inhale. Inhale through the nose, holding the count to five or six seconds. Let the abdomen expand, rather than the chest, and exhale through the mouth one second longer than the inhale.

2. Drink 20 oz. of beet juice. Beet juice contains nitrate, a component that dilates blood vessels and increased blood flow. Participants in a study conducted by St Bartholomew's Hospital in London showed a decrease in blood pressure in less than one hour after drinking 20 oz. of beet juice. In 2.5 years, the participants saw a significant reduction in blood pressure. Warning diabetics this is not good for you as beets have a high in sugar content

3. Take a brisk walk for at least 15 to 20 minutes. While at least

30 minutes of physical activity five days a week can reduce blood pressure overall and is effective for managing hypertension, a patient may not have the time necessary for regular exercise to have a significant effect on blood pressure before a test. However, even a short walk produces rhythmic breathing, which decreases blood pressure by calming the body's stress response. Moreover, the extra oxygen increase helps the heart use oxygen more efficiently, thereby decreasing the stress or pressure on the heart.

4. Drink a glass of water. Water has a calming effect on the nervous system, and water flushes out sodium, an element that increases blood pressure. Drink a larger portion of water at one time, rather than sipping on water at several intervals during the day. Sipping water throughout the day is good for staying hydrated, but for a faster effect on blood pressure, drink a glass of water for direct calming effects and a drop in blood pressure.

5. Eat a banana or other potassium-rich food. Potassium is an electrolyte, and plays a significant role in some of the mechanisms that control blood flow and heartbeat. Potassium supplements may take four to six weeks before having an impact on blood pressure. Depending on how fast the body metabolizes the foods rich in potassium, blood pressure may drop within an hour or two of eating a potassium-rich food.

6. Avoid unhealthy foods and habits before visiting the clinic for testing. Refrain from smoking at least one hour before the appointment, as smoke decreases oxygen intake and makes the heart work harder. Avoid fatty meals, which often contain lots of sodium and increase blood pressure, at least two days before the physical.

7. Avoid soft drinks. Giving up my Mountain Dew and Pepsi was like asking me to give up sex but there's plenty of evidence that the extra calories may boost blood pressure as well. The risk is not entirely new, but the size of the relationship came as a surprise to the researchers, who published their findings in *Hypertension: Journal of the American Heart Association*. Led by Ian Brown, in the department of epidemiology and biostatistics at Imperial College London's School of Public Health, the group found that for every extra sugared beverage consumed, blood pressure — a ratio of systolic and diastolic pressure in the vessels — rose by an average of 1.6 mm Hg and 0.8 mm Hg respectively. While that may not seem like much, says Brown, when you consider that many children and adults down several cans of soda or sweetened fruit juices a day, the numbers can creep up

8. Take a nap before testing or visiting the clinic. Research conducted at the Liverpool John Moores University in Liverpool, U.K., found that naps reduce strain and pressure on the heart. Take a nap, no longer than one hour long, before an appointment for testing.

9. Avoid making a morning appointment and tell the clinician about testing anxiety. Morning hypertension is common, as blood pressure is higher in the morning. More heart attacks occur at 9 am on Monday mornings.

10. Always check with your doctor.

Your feedback on my first article "Your Road Map to Health" is much appreciated

STAY SAFE AND HEALTHY

Contact us at: [roadmaptohealth@gmail.com](mailto:roadmaptohealth@gmail.com)



**Lower your Blood Pressure in 90 days or your money back**

**Learn the ProArgi-9+ Story**



**Dr. Louis Ignarro Ph.D.**  
Nobel Prize - original research

**Dr. Joseph Prendergast M.D.**  
"Father of ProArgi-9+  
More than 20 years of clinical arginine therapy

**Dr. Siva Arunasalam M.D.**  
The most comprehensive human clinical study ever conducted on a nutritional product.

**Dr. Rainer Boger M.D.**  
The most recent arginine research

**Dr. William Keller Ph.D.**  
Lead scientist at Natures Sunshine Products

**Yourroadmaptohealth.com**  
**Yourroadmaptohealth@gmail.com**  
**Steve Lough 608-213-5338**  
**Susan Hossman 847-533-7835**



**Smith Transport**

**EVERY WEEK YOU'LL GET 13 GREAT REASONS TO DRIVE FOR SMITH TRANSPORT**

OUR DRIVERS AVERAGE \$1,300 A WEEK, & THAT'S NOT THE ONLY GREAT REASON TO DRIVE FOR SMITH. WE ALSO HAVE THE BEST EQUIPMENT ON THE ROAD, WITH PLENTY OF FREIGHT, EXCELLENT BENEFITS & GREAT HOMETIME.

**BUILT by a DRIVER for DRIVERS**

866-265-3706  
SmithDrivers.com



**SOCIAL SECURITY DISABILITY BENEFITS.** Unable to work? Denied benefits? We Can Help! WIN or Pay Nothing! Contact Bill Gordon & Associates at 1-800-208-6915 to start your application today!

# Working Show Truck Of The Month - BER Trucking



picturesque PA countryside.

Brian trucks with his stunning, oldschool 1981 KWW-900 A-Model that's about as cool as anything you'll see on the road today. Brian hauls lumber and equipment with his KW and his 1995 Benson flatbed. Even though his truck is 35 years old and has over 1.8 million miles on it, Brian's old school beauty can run with the big dogs!

Power comes from a 3406 E CAT engine that's paired with a 13 speed transmission and a set of 3:55 rears. Brian has added a few custom features to his truck including an 18" bumper, a set of 6" straight pipes, and a set of fenders over the rear tandems. He stretched the wheelbase to 265" and upgraded the power by adding the electronic CAT engine.

He delivers loads to a variety of locations but said his most memorable experience was traveling to Long Island, NY for the very first time. Let's just say that Long Island is a nice place to visit but Brian prefers the countryside of

PA! He has been driving for over 15 years and his old school ride definitely stands out no matter where he goes.

Brian wanted to send a big thanks out to his family for all of their support along the way. He also wanted to thank Darren, Sam, and the Antrim Diesel Shop for everything they've done to keep the wheels turning!

Brian Riechard just may be the definition of "old school cool", trucking around in his 1981 classic KW. While many drivers would prefer a tricked-out new rig with all of the latest features, Brian wouldn't have it any other way. He turns heads on the interstate as well as at the various truck shows he enjoys attending. He has kept the simple, classic KW styling alive and the results speak for themselves!

Movin' Out salutes Brian Reichard for all of his hard work by selecting him as our April 2016 Working Show Truck of the Month.

## By Robert Conrad

As we head into April, 2016 is flying by faster than telephone poles on the side of the highway. Another farming season is beginning to take shape in the regions of the country that are transitioning from Winter to Spring. Farming and trucking are two industries that have been connected forever and will continue to rely on each other.

The owner of our April Working Show Truck is involved in both. Brian Reichard runs BER Trucking based in Chambersburg, PA and he also has his own farm in the





**You don't become the Best Trucker in the World by making poor decisions.**

Behold: James LeRoy. He's the pinnacle of owner-operator success. Many call him the Best Trucker in the World. His crowning achievement? Tired of the hassles and cost of tolls, he did his homework and chose Bestpass. Now, he's saving a king's ransom on tolls and time every single day.

Bestpass is the nation's only coast-to-coast, one-call-fixes-all, loved-by-thousands toll management solution. Nothing else even comes close.

Learn more at [bestpass.com](http://bestpass.com) or call 518.621.5876 and start getting treated like trucking royalty.



# "No time for downtime."

#ROADNATION



**Speedco's en route PM services keep your truck on the road and earning, not waiting.**



**Quick lube, featuring quality oil and filters**

**Tire inspection, replacement, rotation and repairs**

**Federal Annual Inspections**

Featuring  Shell ROTELLA®

Featuring LubeTrak—a quick oil analysis that allows you to reduce maintenance cost, increase machinery lifespan, and detect early warning signs of hidden problems.

Call 1-866-SPEEDCO to learn how we can keep you on the road and earning.

**Visit Us At MATS Booth #16128**